



**S/N :**

***Thank you for purchasing a MINUTEMAN Mixer from an IMER U.S.A. dealer. Your decision is an intelligent one. No other mixer in the world today offers the features and value of the MINUTEMAN Mixer.***

- \* After the initial set-up the MINUTEMAN Mixer can be knocked down or reassembled in 1 minute.
- \* Direct drive drum rotation, efficient and safe.
- \* Portable, the large 12" wheels make moving the MINUTEMAN a breeze around the home or job site.
- \* Compact, the clever design allows the MINUTEMAN to fit into the trunk or hatchback area of almost all cars.
- \* Finish, the high quality of paint and construction components ensure a piece of equipment that you will be proud to own for years.

*At IMER U.S.A. we continually search for ways to better serve our customers. Should you have an idea or thought to share with us regarding this Product we would appreciate hearing from you. Our motto is **"Tools and Services for the 21st Century"**. We look forward to delivering the goods.*

*Thank you again for your purchase,*



*Mace T. Coleman, Jr.  
President, IMER U.S.A. Inc.*

*221 Westhampton Place  
Capitol Heights, MD  
20743  
Ph / 800.275.5463*

## **TABLE OF CONTENTS**

<b>TECHNICAL DATA .....</b>	<b>page 4</b>
<b>NOISE LEVEL .....</b>	<b>page 5</b>
<b>WIRING DIAGRAM .....</b>	<b>page 5</b>
<b>SAFETY NOTES .....</b>	<b>page 6</b>
<b>ASSEMBLY .....</b>	<b>page 7</b>
<b>MOVING THE MINUTEMAN.....</b>	<b>page 9</b>
<b>SETTING UP THE MINUTEMAN .....</b>	<b>page 9</b>
<b>OPERATING THE MINUTEMAN .....</b>	<b>page10</b>
<b>MAINTENANCE AND CLEANING.....</b>	<b>page10</b>
<b>ORDERING SPARE PARTS .....</b>	<b>page10</b>
<b>SPARE PARTS DIAGRAM .....</b>	<b>page11</b>
<b>WARRANTY .....</b>	<b>page14</b>

## TECHNICAL DATA

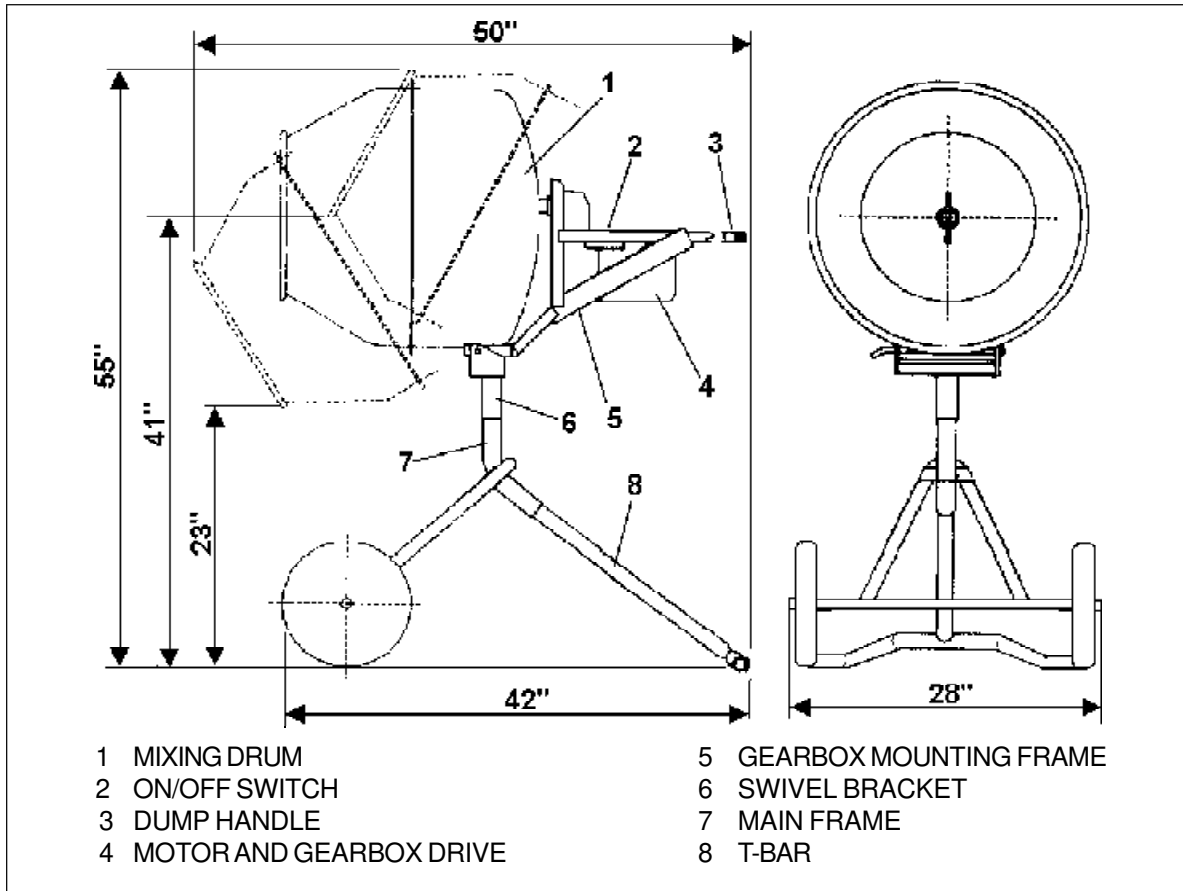

Drum capacity	5 cubic feet
Batch Output	2.5 cubic feet, 225 lbs. *
Drum Diameter	24 inches
Discharge outlet height	23 inches
Wheels	12" x 2.5"
Single Phase electric motor	0.5 HP
Voltage	110 / 115 V
Hertz	60
Motor R.P.M.	3350
Nominal current	6.2 Amp
Operating dimensions	42" x 25" x 58"
Storage dimensions	25" x 25" x 25.5"
Weight	120 pounds

\* Capacities based on usable volume.

Product development and improvement is an ongoing process, therefore, specifications may change without notice.

## NOISE LEVEL

The MINUTEMAN has a noise emission level of 65 decibels. It's very quiet, operate it anywhere.

## WIRING DIAGRAM

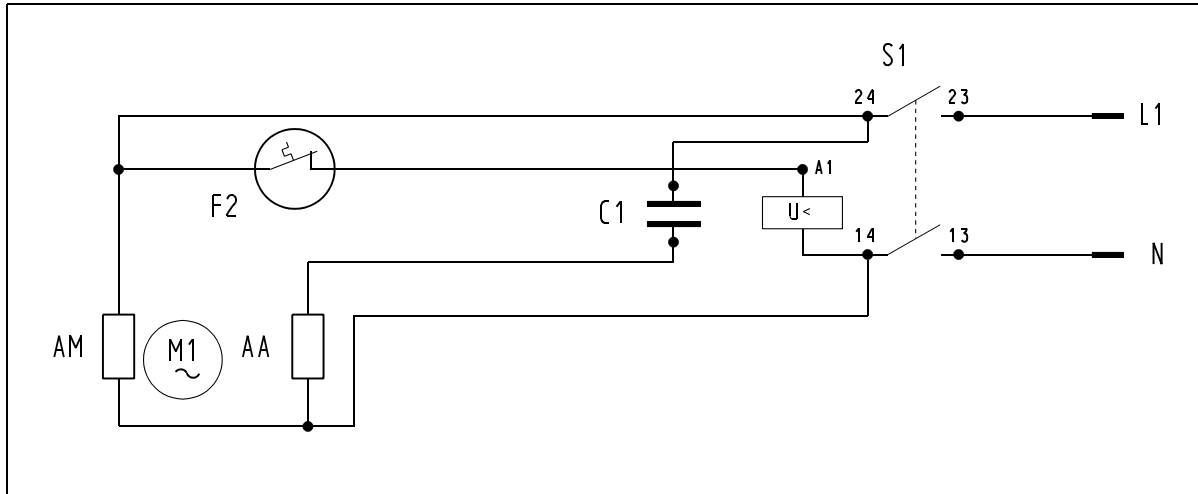

<b>N</b>	<b>Neutral wire</b>
<b>L1</b>	<b>Phase wire</b>
<b>S1</b>	<b>Stop and start button</b>
<b>F2</b>	<b>Thermal protection for electric motor</b>
<b>C1</b>	<b>Capacitor</b>
<b>M1</b>	<b>Single phase motor</b>
<b>AM</b>	<b>Motor winding</b>
<b>AA</b>	<b>Motor winding</b>



*The MINUTEMAN motor is manufactured as a class II Double Insulation type (  ), it does not require a ground wire.*



### **WARNING**

*Any type of electrical repair or trouble-shooting should only be performed by an IMER dealer or a properly qualified electrical repair shop. For assistance with any electrical difficulty, IMER U.S.A. is always directly available @ 800.275.5463.*



***CAUTION:** when carrying out repairs, class II Double Insulation protection will only be maintained if original insulating materials are used and provided the specifications and insulating materials remain unmodified.*

## SAFETY NOTES

# IMPORTANT ! READ THIS SECTION CAREFULLY !

Your **MINUTEMAN** mixer has been designed with safety in mind. However, as with any type of machinery, some basic **DO'S** and **DONT'S** apply:

### DO NOT

*Place your hand or hands in or around any part of the drum while it is operating !*



### DO NOT

*Place any tools or instruments in or around the drum while it is operating !*



### DO NOT

*Operate the mixer on a surface that is not flat or is uneven !*

*Always operate the MINUTEMAN on a level surface, if placed on an incline the machine will fall over.*

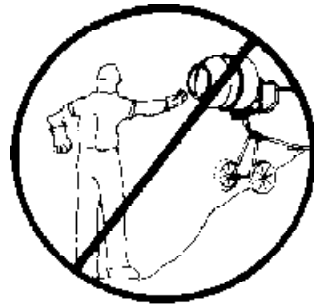

### DO NOT

*Clean, assemble or work on the unit while it is plugged in !*

### DO NOT

*Allow water to contact the motor or electrical connections at any time !*

### DO NOT

*Operate the unit in or around water puddles.*

### DO NOT

*Leave the machine unattended !*

### DO NOT

*Allow other persons around the mixer while it is operating ! Keep children away from your work area !*

### DO NOT

*Operate the mixer while under the influence of alcohol or drugs !*

## **DO NOT**

*Do not start and stop the mixer with material in the drum, this will damage the motor and is not the best way to mix.*

*Always have the drum rotating when filling or discharging the mixer, this produces the highest quality concrete.*

## **SAFETY NOTES**

### **DO**

*Read all the instructions before operating the mixer.*

### **DO**

*Use caution when assembling and transporting the mixer. Tie it down good in your vehicle.*

### **DO**

*Keep the mixer clean and free of debris and mix build-up. After using, fill the drum with water and run the MINUTEMAN for 10 minutes or so, most of the cement will break loose from the drum.*

### **DO**

*Keep all the moving parts lightly lubricated, WD-40 may be sprayed all around the machine (wheel axles, swivel bracket, etc.).*

### **DO**

*Periodically inspect your mixer for abnormal wear or damage. If something does not seem right call your dealer or IMER USA direct @ 800.275.5463.*

### **DO**

*Wear the appropriate safety gear; hard hat ,gloves, goggles, ear protection and wear tight clothing around the mixer. Loose clothing can cause injury should it become entangled with the mixer.*

## **ASSEMBLY - Follow drawings 1 thru 6 -**

**1**

Place the main frame (# 18 Drawing 1) on a level surface as illustrated in this diagram. Insert and secure the T-bar (# 20 Drawing 1) into the main frame with the 3" hex head bolt and nut, using the open wrench provided in the assembly kit.

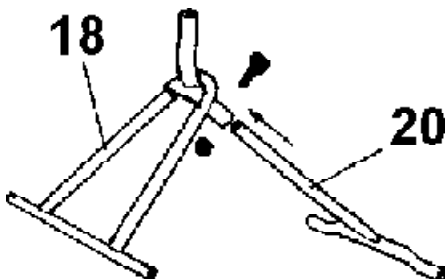

**2**

Slide the wheels (# 8 Drawing 1) onto the main frame bar(# 18 Drawing 1) and anchor them in place with the cotter pins (# 13 Drawing 1) which are included in the assembly kit provided with each MINUTEMAN mixer.

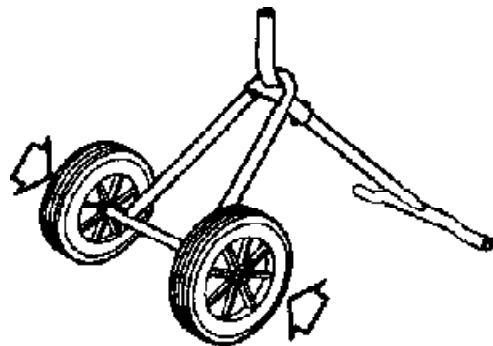

## ASSEMBLY

**3**

Fit the gear-box frame and motor assembly (# 7 Drawing 1) into the swivel bracket (# 15 Drawing 1) with the anchor pin, (# 17 Drawing 1) slide the cotter pin through the anchor pin hole (# 16 Drawing 1).

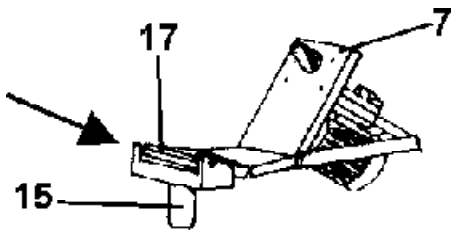

**4**

Slide the swivel bracket (# 15 Drawing 1) onto the main frame upright. The gear-box and motor assembly (# 7 Drawing 1) is mounted into this swivel bracket.

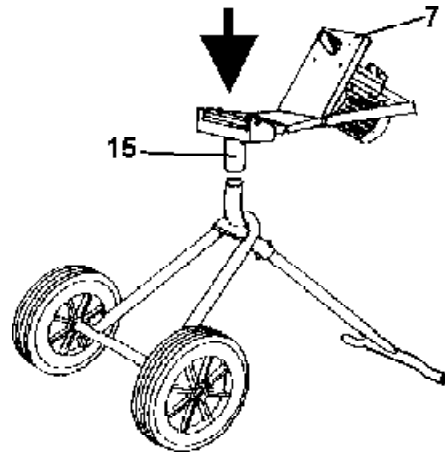

**5**

Mount the mixing drum (# 4 Drawing 1) onto the gear-box shaft (# 29 Drawing 2) by aligning the guide notch with the locating pin on the gear shaft. Secure the drum to the gear-box shaft with the T-handle bolt (# 5 Drawing 1) and washer (# 6 Drawing 1) provided in the assembly kit. Once the T-bolt is tightened as much as possible by hand, give it a whack or two with a hammer: no more, no less.

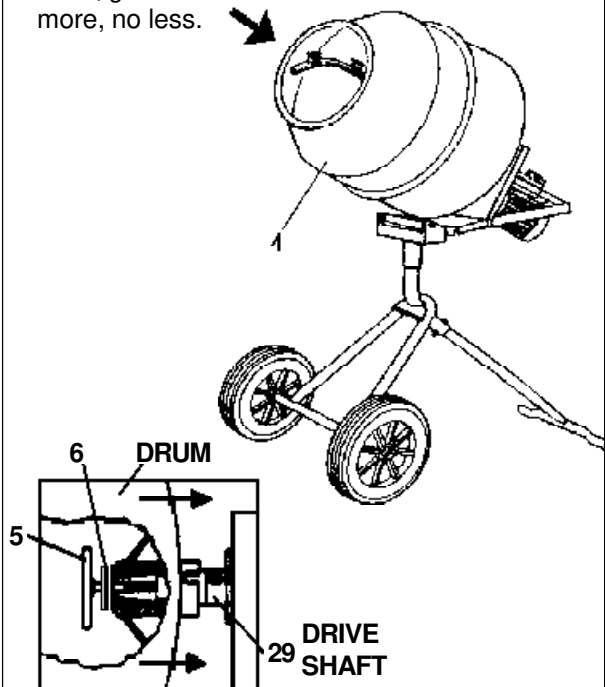

**6**

Secure the mixing blades (# 2 Drawing 1) to the inner drum with the screws (# 1 Drawing 1) and nuts (# 3 Drawing 1) provided in the assembly kit. Assembly with the screws heads on the outer drum.

Finally, insert tilting handle (# 10 Drawing 1) in the handle mounting tube and lock using the cotter pin provided in the assembly kit.

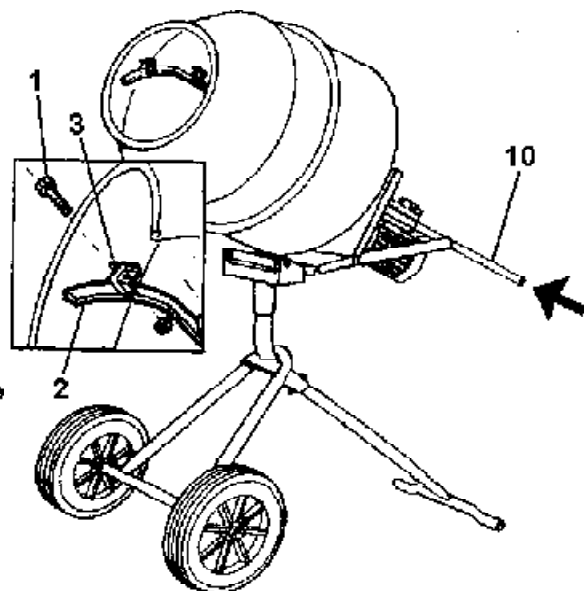



**NO**

**WRONG  
DIRECTION**

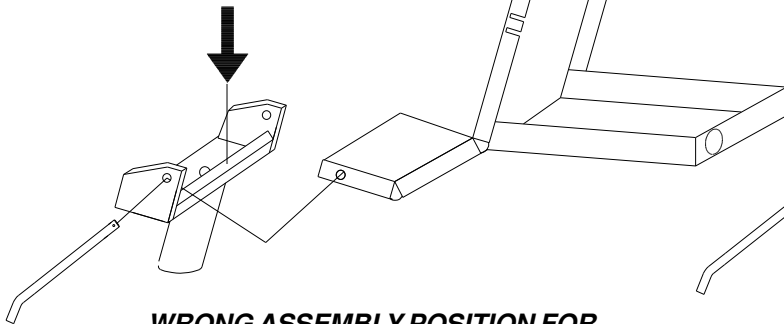

**WRONG ASSEMBLY POSITION FOR  
THE SWIVEL BRACKET**

**YES**

**CORRECT  
DIRECTION**

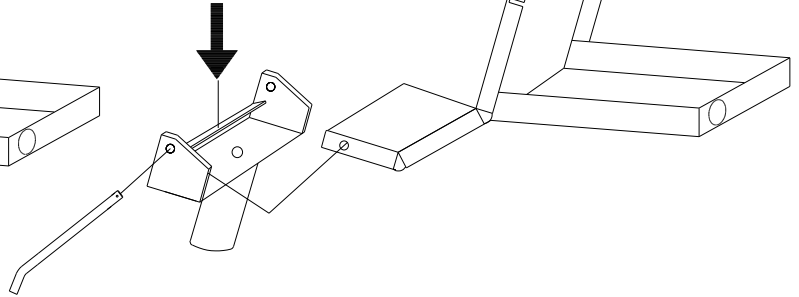

**CORRECT ASSEMBLY POSITION FOR  
THE SWIVEL BRACKET**

### **MOVING THE MINUTEMAN**



**WARNING**

***Always disconnect the power cord before moving the mixer.***

To roll the machine, hold the support leg and dump handle and move as shown in Drawing 4.



**WARNING**

***Do not attempt to move the mixer when there is material in the drum, it must be empty.***

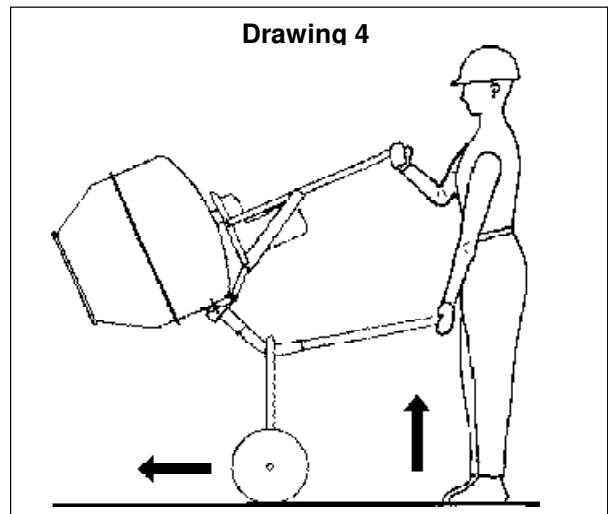

### **CAUTION - SET-UP IMPORTANT**



***Position the machine on a level surface as illustrated in the drawing 6 (maximum allowable slope is 5 degrees, as shown in drawing 6).***



***To complete the mixer set-up, before loading the drum, make sure the mixer can properly discharge into a wheelbarrow.***

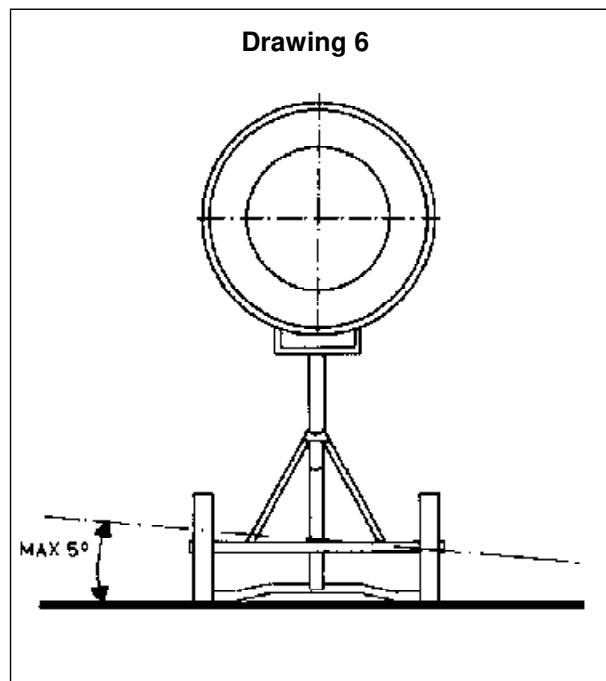

## **OPERATION**

- 1) Use a 2 prong, grounded, 110/115 volt, 60 Hz, power connection for safe operation. The line should be at least 12 gauge.
- 2) To mix concrete, add water, concrete, and aggregate while the drum is rotating.
- 3) Discharge the mixed concrete by elevating the dump handle (# 10 Drawing 1) while the drum is rotating.



***NOTE: When tilting the drum to discharge the concrete, do so slowly. It is important to perform the discharge smoothly, this keeps the machine balanced and upright.***

4) The ON/OFF switch in the motor of the MINUTEMAN mixer provides thermal protection to the motor in the event of overheating. Should your motor shut off automatically, turn off the unit and unplug it for 15 minutes. This allows the motor to cool. After the cooling period, plug in the motor and press the start switch. If the motor does not restart and continue to run, contact your local IMER products distributor, or call IMER direct at 800.275.5463.

## **MAINTENANCE AND CLEANING**

The MINUTEMAN Mixer requires very low maintenance. However, a few basic maintenance procedures should be followed.



***NOTE: Always unplug the mixer from its power source before any cleaning or maintenance functions are performed.***

- 1) Clean the mixer after each use and do not allow any concrete to build up on any portion of the mixer.
- 2) Essentially the gearbox is sealed for life. The quality of the gears and the lubricant are such that changing the oil is not necessary. Should you want to change the oil, see your dealer or call IMER U.S.A direct for instruction @ 800.275.5463.
- 3) Keep all moving parts lightly greased.
- 4) Keep the electric motor cooling fins clean and free of debris build-up.
- 5) Before storing the MINUTEMAN after a project is completed, spray n' wipe the entire machine with WD-40.



***NOTE: When spraying the mixer with water, do not direct the water onto the motor or the ON/OFF switch assembly.***

## **SPARE PARTS**

**All orders for spare parts must include the following:**

- 1) Type of machine.
- 2) Part number and drawing references of each part, see the parts list.
- 3) Serial number and year of manufacture recorded on the machine's identification plate.

DRAWING #1 - FRAME AND DRUM ASSEMBLY			
Ref.	P.n.	Description	NOTE
1	2222193	SCREW	TB M12 x 25
2	2250155	MIXING PADDLE	
3	2223700	NUT	5588 M12 Z
4	2250719	DRUM	
5	2222982	T - BOLT	
6	2224428	WASHER	14X36X6
7	3210935	GEAR BOX FRAME	
8	3206390	WHEEL	
9	2235450	PLASTIC PLUG	
10	3206148	DUMP HANDLE	
12	3210947	I.D. PLATE	
13	2226700	COTTER PIN	
15	3210893	SWIVEL BRACKET	
16	2226702	SPLIT-PIN	1.8/35
17	3210936	PIVOT AXLE	
18	3206365	MAIN FRAME	
19	2222148	BOLT	M10X65 5737
20	2255749	T-BAR	
21	2289740	WRENCH	17X19
22	2223650	NUT	M10 5588
23	3206800	CIRCLIP	M1455 ZA ø14

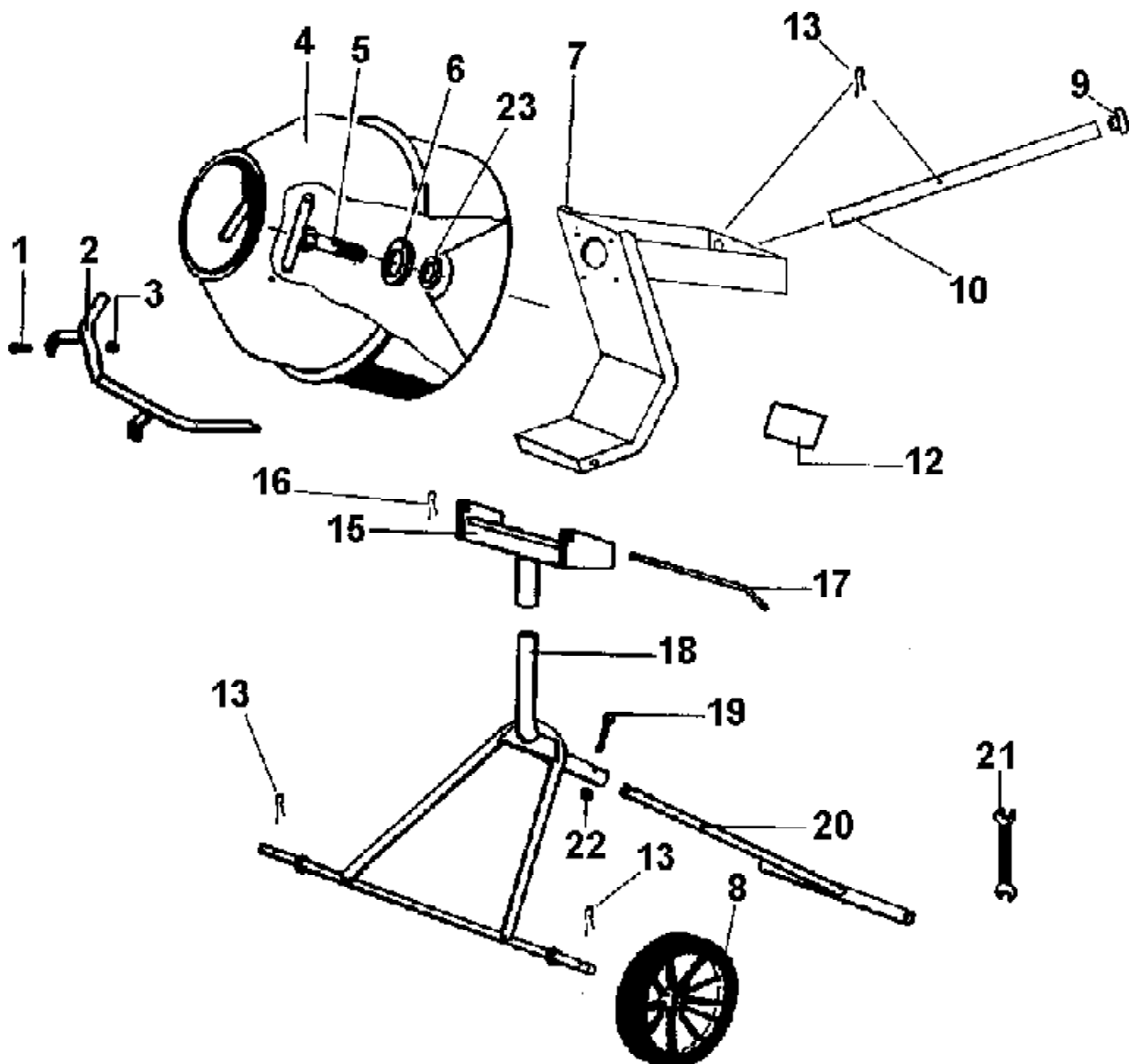

**DRAWING #2 MOTOR AND GEARBOX ASSEMBLY (110/115 V - 60Hz)**

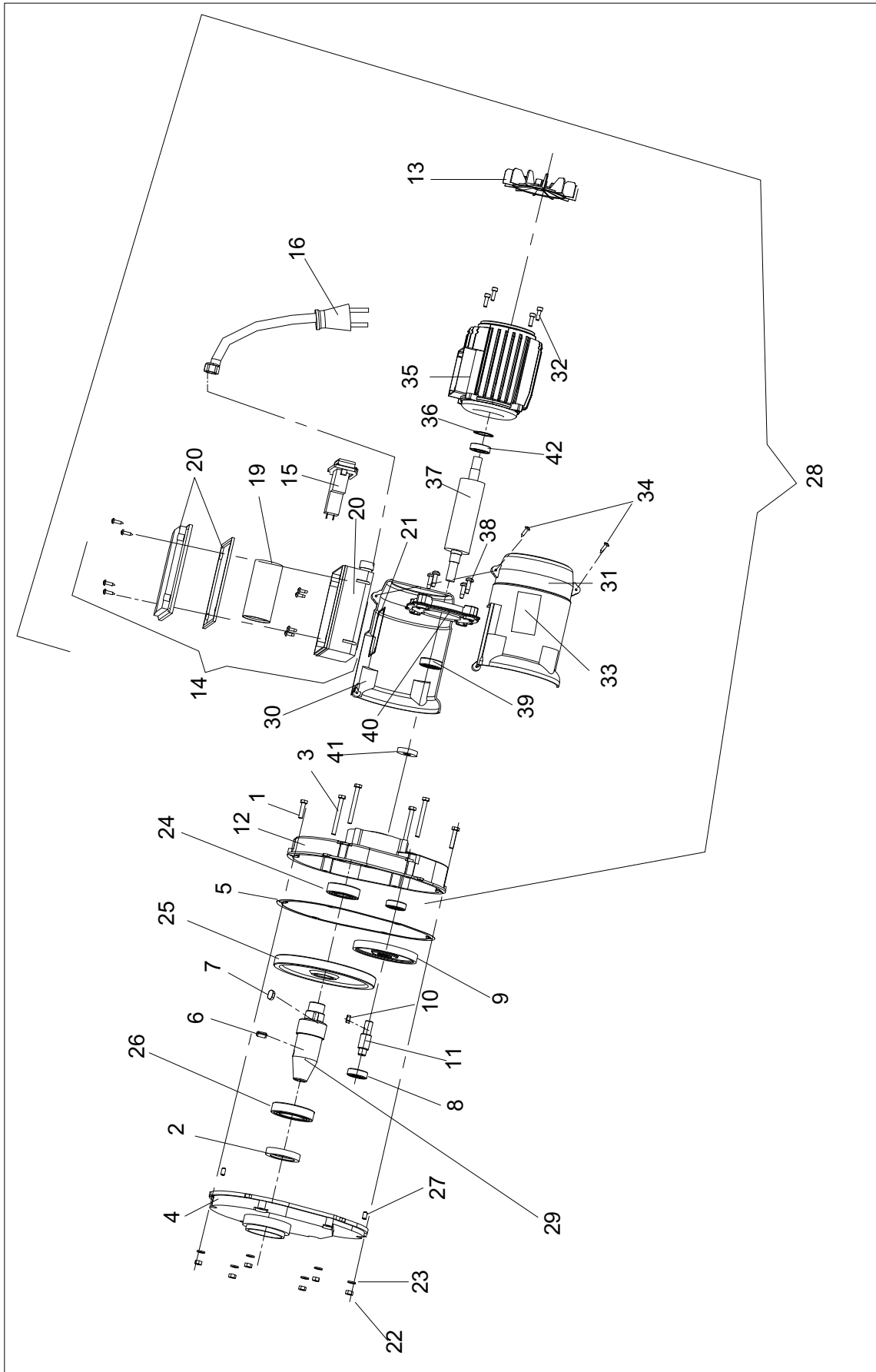



**DIAGRAM #2 MOTOR AND GEARBOX ASSEMBLY**

COD. 3210492 (110 / 115 V - 60 Hz)

UP TO SERIAL NUMBER:	RIF.	P.n.	Description	Note
	1	2222010	BOLT	M6x25
	2	2207405	OIL SEAL	55x40x10
	3	2222012	BOLT	M6x60
	4	3210485	GEARBOX CASE-HALF	
	5	3210482	GEARBOX GASKET	
	6	2228360	SHEAR PIN	Ø8x16
	7	2229500	KEY	8x7x15
	8	2204420	BEARING	6201
	9	3210487	GEAR	Z 81
	10	2229249	KEY	5x5x12
	11	3210483	PINION GEAR	Z 9
	12	3210486	GEARBOX CASE-HALF	
	13	3210904	FAN	
	14	3210911	ELECTRIC BOX COMPLETE (ALL COMPONENTS)	
1005797	15	3210233	SWITCH	
	16	3210955	ELECTRICAL PLUG	
	19	3210923	CAPACITOR	50µF 250 V
1005797	20	3233039	ELECTRIC BOX ASSY + SCREW + GASKET ONLY	
	21	3209214	GASKET	
	22	2223260	NUT	M6
	23	2224530	WASHER	Ø6x12.5
	24	2204550	BEARING	6205
	25	3210479	GEAR	Z 104
	26	2204504	BEARING	6008
	27	2228819	LOCATING PIN	Ø6x12
	28	3210494	MOTOR ASS'Y WITH CASE HALF	
	29	3210481	DRIVE SHAFT SPINDLE	
	30	3210496	RIGHT SIDE MOTOR COVER	
	31	3210495	LEFT SIDE MOTOR COVER	
	32	3210036	SCREW	M5x16
	33	3210587	RATING PLATE	
	35	3210906	STATOR	
	36	3210898	SPACER WASHER	
	37	3210486	ROTOR	
	38	3210901	SCREW	M5x22
	39	3208982	BEARING	6202
	40	3210488	INSULATING FLANGE	
	41	2207350	OIL SEAL	12x32x7
	42	3210902	BEARING	6002



**EQUIPMENT WARRANTY**

**IMER U.S.A. INC.**

**HEADQUARTERS**

*221 Westhampton Place  
Capitol Heights, MD  
20743  
Ph / 800.275.5463*

We warrant to the original purchaser that the IMER equipment described herein (the "equipment") shall be free from defects in material and workmanship under normal use and service for which it was intended for period of one (1) year from the date of purchase by the original purchaser.

Our obligation under this warranty is expressly limited to replacing or repairing, free of charge, F. O.B. our designated service facility, such part of the equipment as our inspection shall disclose to be defective. Parts such as engines, motors, pumps, valves, electric motors, etc. furnished by us, but not manufactured by us, will carry only the warranty of the manufacturer. Transportation charges or duties shall be borne by purchaser. This shall be the limit of our liability with respect to the quality of the equipment.

This warranty shall not apply to any equipment, or parts thereof, which has been damaged by reason of accident, negligence, unreasonable use, faulty repairs, or which has not been maintained and operated in accordance with our printed instructions for the equipment. Further, this warranty is void if the equipment, or any of its components, is altered or modified in any way.

**THIS WARRANTY IS EXPRESSLY IN LIEU OF ALL OTHER WARRANTIES, EXPRESSED OR IMPLIED, INCLUDING ANY IMPLIED WARRANTY OF MERCHANTABILITY OR FITNESS FOR A PARTICULAR PURPOSE.**

We make no other warranty, representation or guarantee, nor is anyone authorized to make one on our behalf. We shall not be liable for consequential damage of any kind, including loss or damage resulting, directly or indirectly, from the use or loss of use of the machine. Without limiting the generality of the foregoing, this exclusion from liability embraces the purchaser's expenses for downtime, damages for which the purchaser may be liable to other person, damages to property, and injury or death of any persons.

This warranty shall not be deemed to cover maintenance parts, including but not limited to blades, belts, hoses, hydraulic oil, or filters, for which we shall have no responsibility or liability whatsoever.