

OPERATION MANUAL



Mikasa SERIES MODEL FU162A HIGH FREQUENCY INVERTER

Revision #0 (05/12/22)

To find the latest revision of this publication or
associated parts manual, visit our website at:
www.multiquip.com



THIS MANUAL MUST ACCOMPANY THE EQUIPMENT AT ALL TIMES.

PROPOSITION 65 WARNING

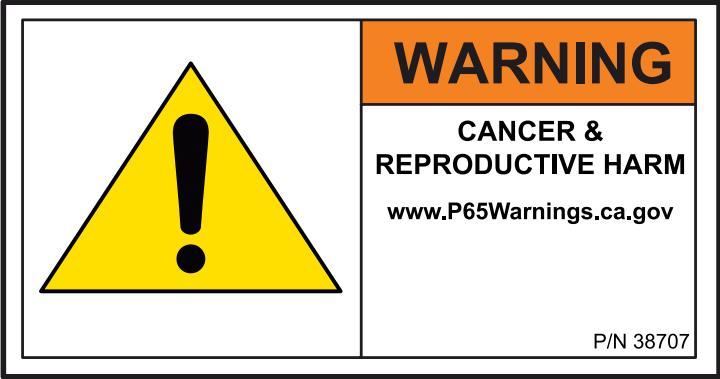

FU162A
High-Frequency Inverter

Proposition 65 Warning 2
Safety Information 4-7
Specifications 8-9
Dimensions..... 10
General Information..... 11
Components 12-13
Inspection 14
Operation..... 15-17
Maintenance 18-20
Troubleshooting 21-27

NOTICE

Specifications and part numbers are subject to change without notice.

SAFETY INFORMATION

Do not operate or service the equipment before reading the entire manual. Safety precautions should be followed at all times when operating this equipment. Failure to read and understand the safety messages and operating instructions could result in injury to yourself and others.



SAFETY MESSAGES

The four safety messages shown below will inform you about potential hazards that could injure you or others. The safety messages specifically address the level of exposure to the operator and are preceded by one of four words: **DANGER**, **WARNING**, **CAUTION** or **NOTICE**.

SAFETY SYMBOLS

! DANGER

Indicates a hazardous situation which, if not avoided, **WILL** result in **DEATH** or **SERIOUS INJURY**.

! WARNING

Indicates a hazardous situation which, if not avoided, **COULD** result in **DEATH** or **SERIOUS INJURY**.

! CAUTION

Indicates a hazardous situation which, if not avoided, **COULD** result in **MINOR** or **MODERATE INJURY**.

NOTICE

Addresses practices not related to personal injury.

Potential hazards associated with the operation of this equipment will be referenced with hazard symbols which may appear throughout this manual in conjunction with safety messages.

Symbol	Safety Hazard
	Lethal exhaust gas hazards
	Explosive fuel hazards
	Burn hazards
	Respiratory hazards
	Accidental starting hazards
	Eye and hearing hazards
	Rotating parts hazards

SAFETY INFORMATION

GENERAL SAFETY

CAUTION

- **NEVER** operate this equipment without proper protective clothing, shatterproof glasses, respiratory protection, hearing protection, steel-toed boots and other protective devices required by the job or city and state regulations.



- **NEVER** operate this equipment when not feeling well due to fatigue, illness or when under medication.



- **NEVER** operate this equipment under the influence of drugs or alcohol.



- **ALWAYS** check the equipment for loosened threads or bolts before starting.
- **DO NOT** use the equipment for any purpose other than its intended purposes or applications.
- **ALWAYS** clear the work area of any debris, tools, etc. that would constitute a hazard while the equipment is in operation.

NOTICE

- This equipment should only be operated by trained and qualified personnel 18 years of age and older.
- Whenever necessary, replace nameplate, operation and safety decals when they become difficult read.
- Manufacturer does not assume responsibility for any accident due to equipment modifications. Unauthorized equipment modification will void all warranties.
- **NEVER** use accessories or attachments that are not recommended by Multiquip for this equipment. Damage to the equipment and/or injury to user may result.
- **ALWAYS** know the location of the nearest **fire extinguisher**.
- **ALWAYS** know the location of the nearest **first aid kit**.
- **ALWAYS** know the location of the nearest phone or **keep a phone on the job site**. Also, know the phone numbers of the nearest **ambulance**, **doctor** and **fire department**. This information will be invaluable in the case of an emergency.

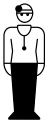

SAFETY INFORMATION

INVERTER SAFETY

DANGER

- **NEVER** operate the equipment in an explosive atmosphere or near combustible materials. An explosion or fire could result causing severe **bodily harm or even death.**



CAUTION

- **NEVER** attempt service on a running machine.

NOTICE

- **ALWAYS** keep the machine in proper running condition.
- Fix damage to machine and replace any broken parts immediately.
- **ALWAYS** store equipment properly when it is not being used. Equipment should be stored in a clean, dry location out of the reach of children and unauthorized personnel.
- **USE** the inverter away from direct sunlight, dust and rain. This product is of dust and water proof structure equivalent to JIS IP56, but if water is splashed during operation or used on water puddle, damage might occur.
- **DO NOT** use more than the maximum number of the vibrators determined and specified for the inverter. If this number is exceeded, malfunction of inverter might occur.
- **DO NOT** use electronic devices such as a computer near the inverter. The noise from the inverter might interfere or damage such devices.
- **DO NOT** use with generators equipped with GFCI (Ground-Fault Circuit Interrupter). Replace with a generator not equipped with GFCI and use it. GFCI has very high sensitivity and high-speed ground-fault circuit characteristics ($5 \pm 1\text{mA}$, 0.25 seconds), so the inverter cannot be started.
- **NEVER** use an inverter that cannot be started or stopped with the circuit protector switch.

ELECTRICAL SAFETY

CAUTION

- Prevent body contact with grounded surfaces such as pipes, reinforcing bar, etc.
- When using inverter, always use grounding wire to prevent electric shock.
- Operate inverter only at the specified voltage indicated on the nameplate.
- **DO NOT** spray water on the machine.
- **DO NOT** yank the cord to disconnect it from the receptacle. Grasp the plug itself to disconnect it.
- **ALWAYS** make sure the circuit protector switch on the machine is in the OFF position when not in use and before inserting the power plug into an AC receptacle.

Power Cord/Cable Safety

DANGER

- **ALWAYS** use a grounded 3-wire extension cord that has a 3-prong grounding plug, and a 3-pole receptacle that accepts the plug on the concrete vibrator motor. **DO NOT REMOVE THE GROUNDING PIN FROM THE PLUG!**
- **NEVER** let power cords or cables **lay in water.**
- **NEVER** use **damaged** or **worn** cables or cords when connecting equipment to generator. Inspect for cuts in the insulation.
- **NEVER** grab or touch a live power cord or cable with wet hands. The possibility exists of **electrical shock, electrocution or death.**
- Make sure power cables are securely connected. Incorrect connections may cause electrical shock and damage to the vibrator motor.

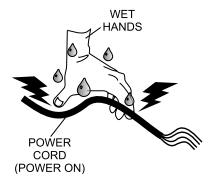

CAUTION

- Ensure that cables and cords will not be tripped over.

NOTICE

- **ALWAYS** make certain that proper power or extension cord has been selected for the job.
- Use only extension cords that are intended for outdoor use and so marked.
- Use only the gauge wire and length of cord recommended for the motor size. If in doubt, go to the next heavier gauge. (The smaller the gauge number, the heavier the cord.)

TRANSPORTING SAFETY

NOTICE

- Do not pull or lift the inverter by the cable only. Cable damage and short circuit might occur.
- Make the cable into a bundle, then hold the middle handle of the inverter when transporting or moving. Make sure that the inverter will not touch the nearby objects such as iron frames and bars.

ENVIRONMENTAL SAFETY

NOTICE

- Dispose of hazardous waste properly. Examples of potentially hazardous waste are used motor oil, fuel and fuel filters. 
- **DO NOT** use food or plastic containers to dispose of hazardous waste.
- **DO NOT** pour waste, oil or fuel directly onto the ground, down a drain or into any water source.

SPECIFICATIONS

Table 1. FU162A Specifications

Input	Phase		SINGLE PHASE
	Voltage	V	100 -120 / 220 - 240
	Current	A	20 / 14
	Input	kVA	2.0 / 2.8
	Frequency	Hz	50 / 60
Output	Phase		THREE PHASE
	Voltage	V	48
	Current	A	19.2
	Input	kVA	1.6
	Frequency	Hz	100 - 240
Dimensions (L x W x H)			12.8 x 9.5 x 9.8 in (324 x 240 x 248 mm)
Total Weight			19.2 lb (8.7 Kg)
Number of Receptacles			2
Ambient temperature condition			14° F to 104° F (-10° C to +40° C)
Ambient humidity condition			80% or less (no condensation)
Overload protection			CURRENT CONTROL
Machine cooling method			FORCED AIR COOLING

SPECIFICATIONS

Table 2. Cord Size

Size of Power Cord	Length of Extension Cord (between inverter and vibrator)	
	Single phase (100 - 120V)	Single phase (220 - 240V)
AWG14	46 ft (14 m)	66 ft (20 m)
AWG12	82 ft (25 m)	115 ft (35 m)
AWG10	125 (38 m)	180 ft (55 m)
AWG8	183 ft (56 m)	262 ft (80 m)

Table 3. Number of Vibrators Allowed

Frequency Inverter	Vibrator			
	FX30E6	FX40G6	FX50G6	FX60E6
FU162A	4	3	2	1

DIMENSIONS

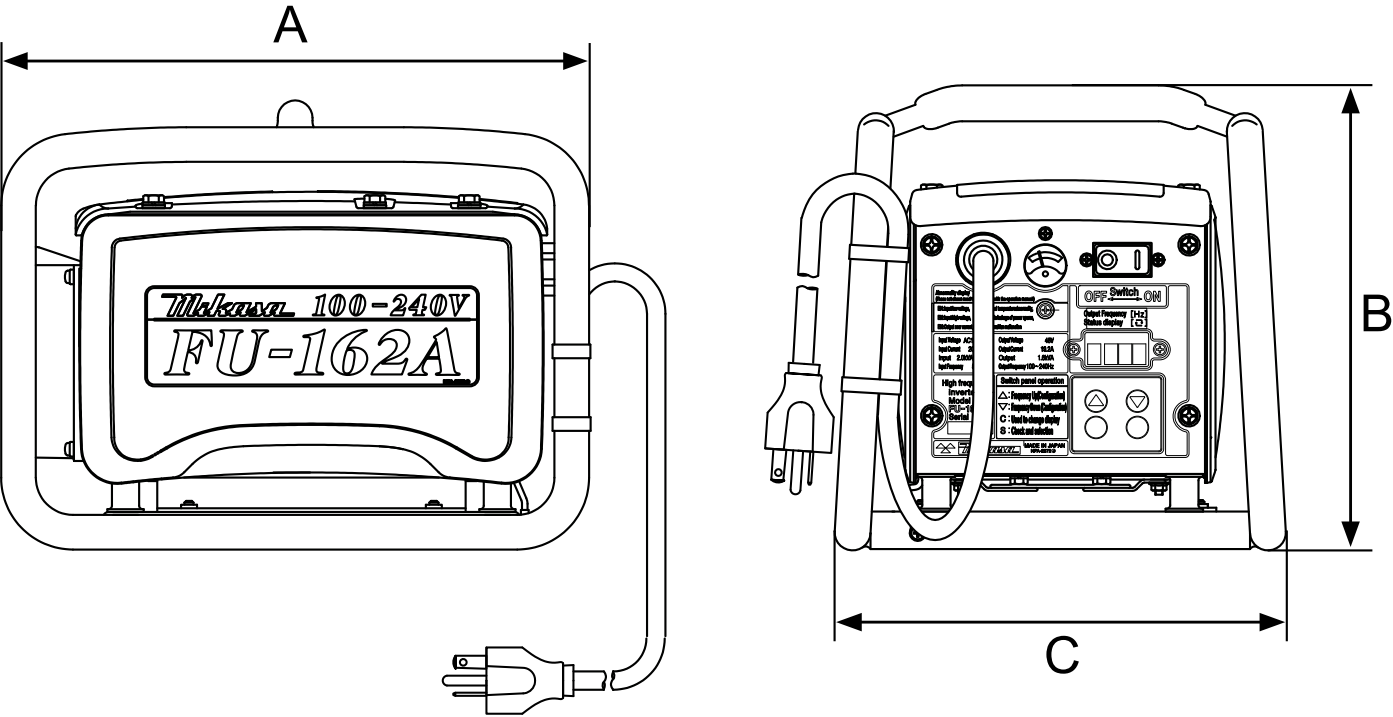

Figure 1. FU162A Dimensions

Table 4. Dimensions		
Reference	Description	Measurement
A	Length	12.8 in (324 mm)
B	Height	9.8 in (248 mm)
C	Width	9.5 in (240 mm)

GENERAL INFORMATION

DEFINITION OF INVERTER

The Mikasa FU162A with built-in high frequency induction motor, is a special inverter to convert single phase AC 80-130V and single phase AC180-250V power to the voltage and frequency suitable for use by a high frequency vibrator.

The output frequency can be varied from 100Hz to 240Hz. This small and light weight inverter is portable, and it is suitable for use at every concrete casting site.

COMPONENTS

Electric parts other than the external cooling fan, output outlet and power cable are placed inside the dust and water proof box. For protection of the box, a pipe frame is provided.

The power cable led inside the box is connected to the relay substrate. Via the relay substrate, the cable is connected to the circuit protector, then to the voltmeter. The output from the circuit protector is connected to the output outlet via the rectifier, smoother, inverter circuit, and control circuit.

POWER TRANSMISSION

This machine converts the commercial power or single-phase AC power from a generator into direct current. The direct current is then converted again, by electronic control, to high frequency AC power suitable for a high frequency vibrator.

Commercial power (single-phase AC) enters through the power cable, and when the attached breaker switch is turned on, electric current flows through the circuit. This current is converted to direct current via the rectifier and the condenser. This direct current is converted again by the transistor switching control to alternate current suitable for a high frequency vibrator. The power is sent to the output outlet and the power is supplied to the high frequency vibrator.

APPLICATION AND TECHNIQUES

A high frequency vibrator can be connected to the inverter. This machine should only be connected to the specified high frequency vibrators.

As input power source, use general commercial power and power generator that is equivalent to the general commercial power. Do not connect to other power sources. Also, do not use this machine beyond the allowable input voltage of the inverter. Otherwise, the vibrator and the inverter will be damaged.

Do not try to connect to a vibrator having a motor with different specification by altering the plug and the outlet for connection. The vibrator and the inverter might get damaged, and also there is a danger of electric shock.

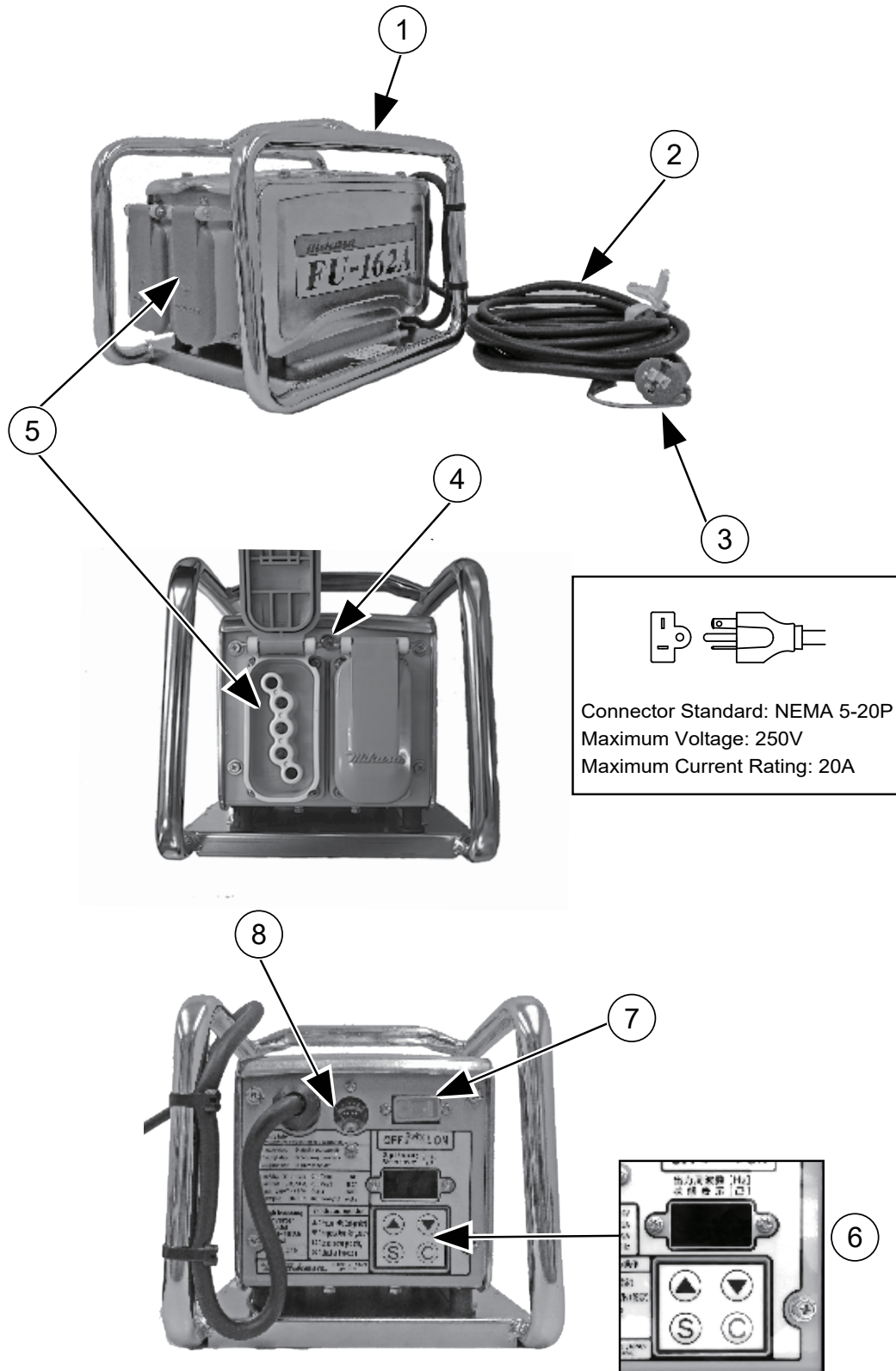

Figure 2. FU162A Controls and Components

COMPONENTS

Figure 2 shows the location of the basic controls and components of the FU162A Inverter. The function of each control is described below:

1. **Guard Frame** — Protects the components of the frequency inverter.
2. **Power Cable** — Connects the inverter to the power plug.
3. **Power Plug** — Connects to the power source.
4. **LED** — Green LED lamp lights up when at normal voltage range. If the green or orange LED lamp is blinking or the red LED is ON, abnormality in power source is detected. Stop using immediately.
5. **Outlet** — Connects the vibrator to the inverter.
6. **Frequency Adjustment /Abnormality Display Switch** — The display indicates operation frequency, input voltage, output current, input current in normal mode. When there is an abnormality, an error number is indicated.
7. **Circuit Protector Switch** — Check to make sure that the switch is always turned off when machine is not in use. If you insert the power plug into the power outlet when switch is turned on, the vibrator connected to the inverter might start suddenly, which might cause an accident.
8. **Voltmeter Input** — Indicates the input voltage. Make sure voltage is in the green zone.

BEFORE STARTING

1. Read safety instructions at the beginning of manual.
2. Check power plug and contact for dirt, rust, deformation and breakage.
3. Check power cable for wear, crushing, crack, etc.
4. Open the output outlet cover to check inside and terminal part for dirt, etc. Check bolts and nuts used on inverter for looseness, deformation, etc. Also check the output outlet cover for smooth open/close movement.
5. Check circuit protector switch to see if it properly switches ON and OFF, and the green LED turns ON. After inspection, always turn the switch OFF.
6. Connect to a vibrator and check to see if the vibrator operates normally.
7. Check anti-vibration rubber for deformation and cracks.
8. Check conduction resistance between power plug contacts when circuit protector is OFF.

For safety purpose, the input voltmeter needle moves when the power plug is inserted into the power source outlet even if the circuit protector is turned OFF.

Measure conduction resistance between power plug contacts. The tester needle will point to around 200 to 300 Ω . This is the impedance (resistance) of the voltmeter, not conduction trouble. This value pointed by the tester may vary slightly depending on the detection method and accuracy of the tester.

OPERATION

1. Check to see if the power source matches the specification of this inverter and the voltage is within the normal voltage range of this product. When a generator is used, check to see if it is of or above the rated output shown in Table 6.

Table 5. Power Source Specifications			
Model	Frequency	Voltage	Current
FU162A Single-Phase (AC)	50/60Hz	100V	20A
		120V	16A
		200V	14A
		240V	10.5A

2. Connect the power plug to the power source, then check to see if the voltmeter on the inverter shows a value within the green zone (Table 6). Always connect the grounding wire. For single phase 100V outlet of non-grounding type (without grounding wire), use the grounding clip attached to the power plug to connect to the grounding wire.

Table 6. Power Source Voltage		
Model	Power Source Specifications	Voltage Range
FU162A Single-Phase	50/60Hz 100-120V	80-130V
	50/60Hz 220-240V	180-250V

NOTICE

If used at a voltage exceeding values shown in Table 6, the inverter board and parts may be damaged.

If the voltage used is low, the inverter output gets lowered and the performance of the concrete vibrator will also be lowered, making it difficult to do efficient concrete consolidation. Also, the inverter substrate and parts might be damaged.

3. Turn on the inverter circuit protector switch (Figure 3). Make sure that the cooling fan starts and the green LED lamp lights up (normal voltage range). If the green or orange LED lamp is blinking or the red LED is lighted, some abnormality has been detected in the power source. Stop using immediately and correct the cause of abnormality before operation.

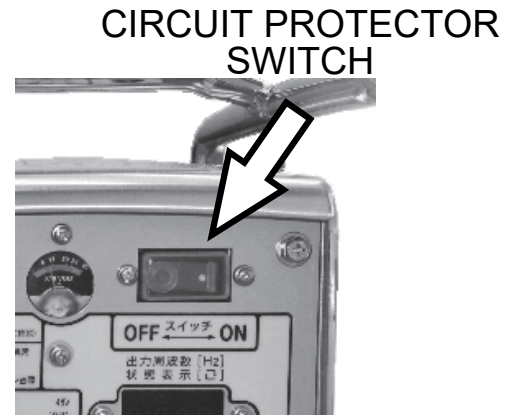

Figure 3. Circuit Protector Switch

NOTICE

Do not use the same power source used by the inverter for other electronic devices such as a computer. The noise from the inverter causes interference and damage might occur in the electronic device.

4. When the inverter circuit protector switch is turned on, frequency (when normal) is displayed at the Frequency Adjustment/Abnormality Display (Figure 4).



Figure 4. Frequency Display

CAUTION

When using FX Series of high frequency vibrators, always use the frequency of 240 Hz. Do not set to the frequency other than 240 Hz.

NOTICE

If error code is indicated on the Frequency Adjustment/ Abnormality Display instead of the frequency, see section on Abnormality Indication Display Function.

- After frequency is displayed, the power source condition and output current can be checked by pressing the C button (Figure 4). See for the sequence of displays.

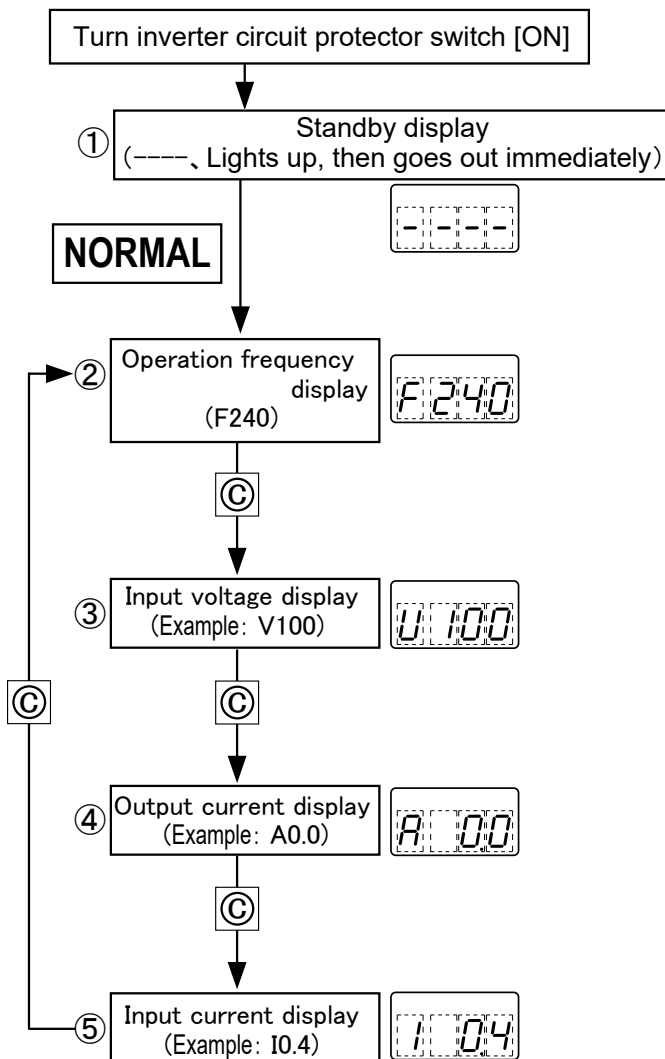

Figure 5. Power Source Condition and Output Current Check

- Make sure that the switch of the work machine (vibrator), is turned off.
- Insert the male plug of the work machine securely into the end of the inverter output outlet (Figure 6).

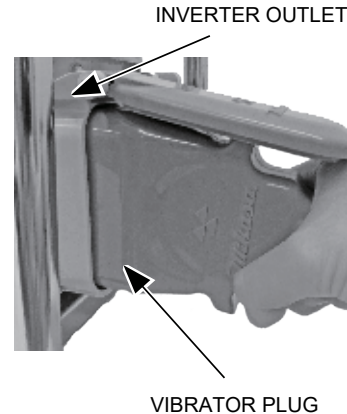

Figure 6. Connecting Work Machine to Inverter

- Check to see if the output outlet cover claw is properly engaged into the male plug, and it does not come off when pulled lightly (Figure 7).

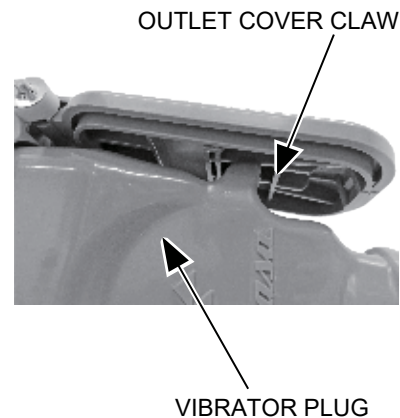

Figure 7. Output Outlet Cover Claw

- Hold the hose and hang the vibration head (vibrator end portion) of the vibrator. When doing so, make sure there is no person or obstacle nearby and it is safe to operate.
- After reconfirming that the inverter input side power voltage is in the normal voltage range and the green LED lamp is lighted, turn the switch of vibrator on one after another to start casting.
- During your work if the vibrator starts to pulsate and the green LED lamp starts to blink or the red LED lights up,

abnormality might have occurred in the power source or in the machine. Correct the cause of the trouble before resuming work.

12. After the casting work is finished, turn off the switch of vibrator one at a time.
13. Unplug the vibrator male plug from the inverter output side outlet. Because the output outlet cover claw is catching the plug, raise the cover to disengage the claw before unplugging (Figure 8).

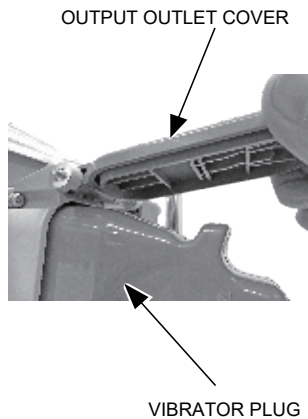
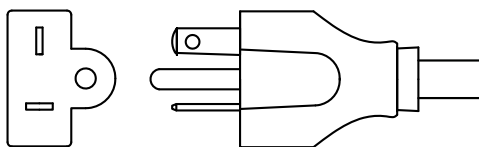

Figure 8. Raising the Output Outlet Cover

14. Turnoff the inverter circuit protector switch and unplug the power plug (Figure 9). When unplugging, do not hold the cable. Problems such as cable breakage might occur.



Power plug
for single phase 250V

Figure 9. Inverter Power Plug

ABNORMALITY INDICATION DISPLAY FUNCTION

After the inverter circuit protector switch is turned on and an error occurs, error code is displayed on the Frequency Adjustment/Abnormality Display. If that happens, check the description of the error and correct the cause of abnormality. See Figure 10 for Error Sequence.

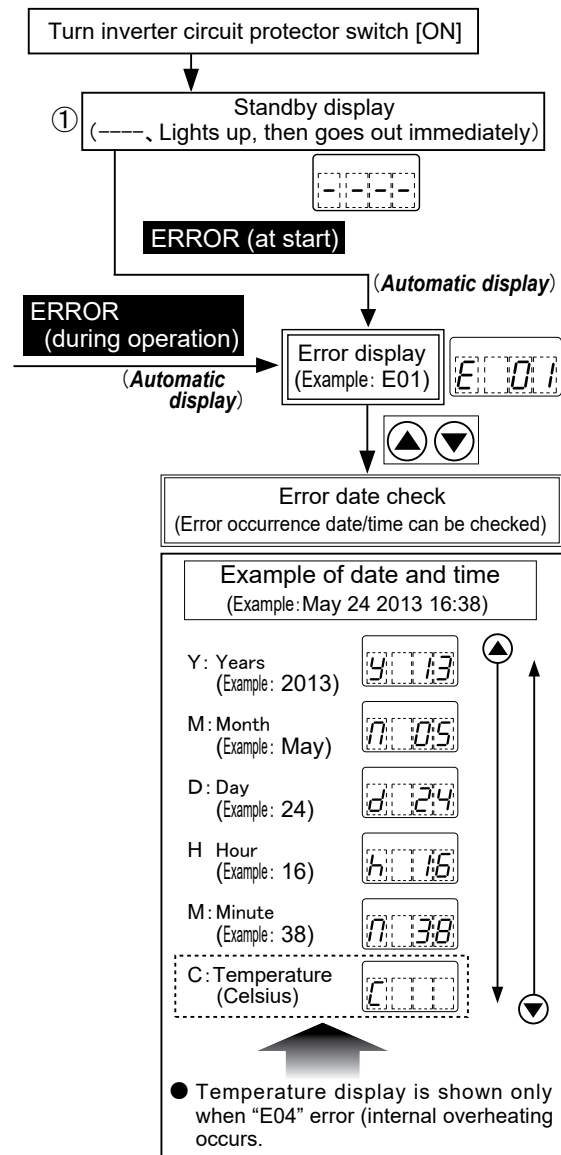

Figure 10. Error Display

15. For details of error display, please refer to Error List Table.
16. After the cause of the error is corrected or removed, the regular display appears automatically.

Check the following items before and after use.

1. Check power plug and contact for dirt, rust, deformation and breakage.
2. Check power cable for wear, crushing, crack, etc.
3. Open the output outlet cover to check inside for dirt.
4. Check terminal part for dirt.
5. Check bolts and nuts used on inverter for looseness or deformation. Also check the output outlet cover for smooth open/close movement.
6. Check circuit protector switch to see if it properly switches ON and OFF, and that the green LED turns ON. After inspection, always turn the switch to OFF.
7. Connect to a vibrator and check to see if the vibrator operates normally.
8. Check anti-vibration rubber for deformation and crack.

While doing concrete consolidation, promptly remove the concrete that splashes on the inverter. When washing the inverter with water, pay attention to the following point. Do not wash with water if there is deformation or breakage on the inverter, or when the female panel outlet cover does not close securely.

1. Check the bolts, screws, switches and input cable of the inverter for looseness.
2. Check the parts of the inverter (front panel, switch panel, top surface cover, side surface cover) for deformation and crack. If there is deformation or breakage, dust and water proofing performance will be lowered, and water might enter inside during washing with water, leading to trouble of electronic parts.

3. Check the output side outlet cover to make sure it closes. If it does not close properly, water might enter inside through the terminal part. When washing, close the output side outlet.
4. When washing, keep the inverter in the upright position while splashing water from the top. If washed with the inverter set on its side or put upside down, the cooling fan will be immersed in water, leading to malfunction of the fan. Do not put water nozzle directly to the intake/exhaust holes at the bottom.
5. Pay attention to the amount and pressure of the water used for washing to maintain them at the level specified by JIS standard IP56. See Notice.

NOTICE

The first number “5 (IP5X)” indicates class 5 of dust proof structure protection class (no effect on machine when exposed in talc dust for 8 hours), and the ending number “6 (IPX6)” indicates class 6 of water proof performance protection class (no abnormality in the machine when the machine body installed normally is injected with water from outside from every direction for more than 3 minutes at a rate of 100 liter per surface area of 1m² per minute with a water spray nozzle having a diameter of 12.5 mm positioned 2.5 to 3.0 m away from the machine body).

CAUTION

After washing, wipe off the water and let the inverter dry. Wipe off water also from the inside of the output side outlet cover and the terminal holes. If there is remaining water, electric shock and electric leak might occur.

INPUT POWER VOLTAGE CONDITION/ ABNORMALITY INDICATION FUNCTION

Input power voltage condition display function

The FU162A inverter has three-color high-intensity LED lamps on the panel outlet side of the main unit, to display input power voltage condition and inverter abnormality in four different modes. In addition, at the time of abnormality, the frequency display function on the back surface of the inverter is switched to LED to show error situation. See Table 7.

As a function of the FU162A, in addition to the blinking of LED lamp, the vibrator will be pulsed by the inverter control when the power source voltage is abnormally low to warn the worker of abnormality by sound and vibration.

Table 7. Input Power Voltage Condition

Input Voltage	LED Status	Voltage	Current
		Single Phase 100 - 120V	Single Phase 220 - 240V
Normal voltage	Green light ON	About 80 - 130V	About 180 - 250V
Warning voltage	Green Blinking	About 70 - 80V and About 130 - 140V	About 160 - 180V and About 250 - 260V
Abnormal voltage	Orange Blinking	About 60 - 70V* and About 140 - 160V	About 140 - 160V and About 260 - 270V
Stop voltage	Red Light ON	About 60V or less and About 270V or more (Error display: E01,E02)	

* High frequency vibrator • self vibrating motor pulsates.

NOTICE

When the power source is a generator and there is a waveform feed or damage/wear problem with the the generator, you might not be able to get a proper reading of the display functions. This is an issue of the generator and not the inverter.

Table 8. Abnormality Indication Display Function

Abnormal Condition	LED Status	Description of Display (lighting)	Error Display FU162A
Load Side Abnormality or Machine Body Abnormality	Red light ON	Input voltage drop	E01
		Load short	E03 or E13
		Internal overheating	E04
		Power source electric leak	E05*
		External fan malfunction	E08
	Abnormality (substrate trouble, etc)	E15 - E26	
	Green light ON	Battery error	E14

* If leakage has begun, there are times when error memory E05 is insufficient power supply time.

Table 9. Error Countermeasures

Error (LED Display)	Description	LED Status	Machine Behavior	Countermeasure	Inverter restart method and required action
E01 Blinking	Input low voltage	Red light ON	Output stop	Power source inspection/replacement	Inspection/replacement
E02 Lights up and immediately goes out	Input high voltage	Red light ON and immediately goes off	Inverter stop and circuit protector OFF	Power source inspection/replacement	Circuit protector ON again
E03 Blinking	Output overcurrent	Red light ON	Output stop	Machine body inspection/repair and replacement	Circuit protector OFF then ON again
E04 Blinking	Internal overheating	Red light ON	Output stop	External fan and other inspection	After machine cools down, circuit protector OFF then ON again
E05 Lights up and immediately goes out	Power source electric leak	Red light ON and immediately goes off	Inverter stop and circuit protector OFF	Electric leakage location, inspection and repair, or power source change	Circuit protector ON again
E08 Blinking	External fan malfunction	Red light ON	Output stop	External fan inspection/change	Circuit protector OFF then ON again
E14 Blinking	Battery charging capacity insufficient	Green light ON	_____	Installed battery change	_____
E15 - E26 Blinking	Abnormality of machine body	Red light ON	Inverter stop and circuit protector OFF	Immediately stop using, machine body inspection and repair	Inspection or repair without doing restarting

TROUBLESHOOTING

Troubleshooting (Frequency Inverter)		
Symptom	Possible Problem	Solution
The Inverter Does Not Run Even When The Circuit Protector Switch Is ON (No Power)	Input plug is not connected to the power source?	Connect to the power source that matches the rating of the machine.
	Main power is cut. (Main breaker is OFF)?	Turn on the main power [main breaker ON].
	Power cable of this machine is broken [open phase] or short circuit inside the input plug mold?	Replace or repair power plug or power cable. Depending on the failure condition, replace or repair the substrate assembly. LED lamp does not light up, with no error display.
The Inverter Does Not Run Even When The Circuit Protector Switch Is ON (Power is turned on and circuit protector is on)	Power cable of this machine is broken [open phase] or short circuit inside the input plug mold?	Replace or repair power plug or power cable. Depending on the failure condition, replace or repair the substrate assembly. LED lamp does not light up, with no error display.
	Voltmeter does not give normal display?	Change the voltmeter.
	Circuit protector switch breakage?	Immediately stop using, and inspect the wiring and control substrate. Replace the circuit protector (depending on the breakage condition, the substrate may be replaced.)
	External cooling fan malfunction?	Replace the cooling fan assembly (red LED lamp ON, abnormality description [error display: External fan - E08] is displayed, output of the machine stops.)
	Frequency display substrate trouble (breakage, damage)?	Immediately stop using, replace the frequency display substrate assembly (LED lamp OFF, no error display)
	Power source and control substrate trouble (mounted parts and circuit breakage, etc.)?	Immediately stop using, inspect and repair the machine (red LED lamp ON, abnormality description [error display: E15-E26] is displayed to indicate trouble situation, output of the machine stops. However, depending on the trouble condition of the substrate, LED lamp OFF and no error display.)

TROUBLESHOOTING

Troubleshooting (Frequency Inverter)		
The Inverter Does Not Run Even When The Circuit Protector Switch Is ON (Power is turned on and circuit protector is off)	Circuit protector switch is not ON?	Circuit protector switch ON.
	Circuit protector switch is not functioning?	Immediately stop using, inspect the wiring and control substrate, replace the circuit protector switch assembly (depending on the condition of breakage, the substrate may be replaced.)
	Power source and control substrate trouble (mounted parts and circuit breakage, etc.)?	Immediately stop using, inspect and repair this machine. (When the circuit protector switch is OFF due to the substrate trouble, LED lamp OFF and no error displayed.)
The Inverter Does Not Run Even When The Circuit Protector Switch Is ON (Power is turned on and circuit protector turns off)	Machine dropped or strong impact applied?	Before turning on the input power, check outside and inside of this machine for damage and break-age. Turn on power after safety is checked. If abnormality is detected, immediately stop using, then inspect and repair.
	Circuit protector failure	Immediately stop using, inspect the wiring and control substrate. Replace the breaker switch assembly (depending on the condition of breakage, the substrate may be replaced.)
	Power source electric leakage (inside the machine or vibrator side)	Immediately stop using, check the area of electric leakage and replace or repair this machine. After LED lamp lights up, it immediately goes out. Abnormality description [error display: E05] is saved, and circuit protector switch is automatically turned OFF, this machine stops.
	Input power high voltage	Stop your work. After checking the power source voltage, correct the situation that has caused power source voltage drop or replace power source. After the red LED lamp lights up, it goes out immediately. Abnormality description [error display: E02] is saved, and the circuit protector switch is turned off automatically, then the machine output stops.
	Power source and control substrate trouble [mounted parts and circuit breakage, etc.]	Immediately stop using. Inspect and repair this machine. (When the circuit protector switch is turned OFF by the failure of the substrate, LED lamp does not light up and no error display is shown.)

TROUBLESHOOTING

Troubleshooting (Frequency Inverter)		
Water (liquid) and dust gets in the machine.	Immersion in water due to mud flow, mud water and dirty water by natural disaster and accident?	Never turn on the power. Danger of electric shock and electric leakage. With the power off, contact our parts service center for inspection and repair.
Damage, deformation, breakage of the inverter.	Breakage and deformation of output panel outlet and housing?	Never turn on the power. Danger of electric shock and electric leakage. With the power off, contact our parts service center for inspection and repair.
	Deterioration and breakage of water proof packing and seal of each part?	
	Insufficient tightening or non-tightening of fastening bolts used on the top surface cover and side surface cover at the time of repair and inspection?	
Cooling Fan Trouble (Power is not on)	Power plug is not connected to the power source?	After making sure the machine switch is OFF, connect to the power source. (If the switch is ON, always turn it OFF.)
Cooling Fan Trouble (Power is on, inverter starts, revolution of external cooling fan fluctuates)	Fan revolution fluctuates from high speed to low speed?	Cut the power source, then check the fan rotation part for foreign object (string-like) that might be trapped there. If trouble is found, immediately stop using and replace the fan.
Cooling Fan Trouble (Power is on, external cooling fan does not run)	Cooling fan power relay connector is not connected?	Check the relay power connector for breakage and damage. If there is no abnormality, reconnect. (LED lamp is OFF. Reconnect. If the machine does not run, inspect and repair. If continuously used with the fan stopped condition, with the increase in the internal temperature, the red LED lamp will turn ON. Abnormality is displayed [error display: E04 or E08] to show the condition. Output of this machine stops.)
	Cooling fan wiring is broken or short circuited?	Repair the broken part, paying sufficient attention to waterproofing, or replace the cooling fan assembly and wiring assembly with relay connector. (red LED lamp turns ON. Abnormality description [error display: E08] is displayed to show the condition of breakage. Output of this machine stops.)
	Cooling fan power relay connector is broken, damaged or dirty?	Replace the wiring assembly having relay connector and cooling fan assembly

TROUBLESHOOTING

Troubleshooting (Frequency Inverter)		
Cooling Fan Trouble (Power is on, external cooling fan does not run)	Cooling fan rotation part was broken, damaged or deformed because of the foreign matter entered into the cooling fan rotation part or because the machine was dropped or a strong impact was applied to it, which results in rotation lock and abnormal drop of revolution?	Replace cooling fan assembly.
	Burning of cooling fan motor and fan substrate breakage?	
	Damage caused by water (sewage water, washing water, and mortar) getting into cooling fan?	
Machine Operation Trouble (power is not on)	Power plug is not connected to the power source?	After making sure the vibrator switch is OFF, connect to the power source. (If the switch is ON, always turn it OFF.)
Machine Operation Trouble (power is on but machine does not run)	Output plug is not connected?	After turning the machine switch OFF, connect the output plug.
Machine Operation Trouble (power is on but machine does not run, output plug of machine connected)	Machine switch is not turned ON?	Turn the machine switch ON.
	Output overcurrent (machine failure, wrong connection or contact problem of male plug and output outlet)?	Inspect the vibrator. Check for damaged machine, and after checking, replace or repair the damaged machine. Check the male plug and output outlet terminal contact for damage. Replace or repair. (Red LED lamp turns ON. Abnormality description [error display: E03-E13] is displayed. Output of this machine stops.)
	Input power low voltage?	After checking the power source voltage, increase or correct the voltage or replace the power source. (Red LED lamp turns ON. Abnormality description [error display: E01] is displayed, output of this machine stops. After the power source voltage increases, this machine automatically resumes its operation.)

TROUBLESHOOTING

Troubleshooting (Frequency Inverter)		
Machine Operation Trouble (power is on but machine does not run, output plug of machine connected)	Input power high voltage?	Stop your work, and after checking the power source voltage, lower the voltage or replace the power source. (Red LED lamp turns ON then goes out immediately. Abnormality description [error code: E02] is saved. Breaker switch is turned OFF automatically. This machine stops.)
	Power source and control substrate trouble (mounted parts and circuit breakage)?	Immediately stop using. Inspect and repair this machine.
Power is turned on, but the machine operation is not stable, and the revolution is low.	Input power voltage low?	After checking the power source voltage, increase or correct the voltage or replace the power source. (Green or orange LED lamp blinks. When the orange lamp is blinking, the vibrator pulsates.)
	Power source and machine extension cable [primary side] are not connected?	Check the operation section. Make sure the length and size of the extension cable are appropriate, and if not appropriate, replace the cable. (When power source voltage is low only at the primary side, the green or orange LED lamp blinks and the vibrator starts to pulsate. If it is at the secondary side, LED lamp does not blink and the vibrator does not pulsate.)
	This machine and vibrator side extension cable [secondary side] are not connected by a cable of appropriate length and size?	
	The number of various vibrators connected to this machine exceeding the allowable number of vibrators that can work with this machine?	Check the number of vibrators that can be connected by reading the vibrator nameplate on the top surface of this machine. Make adjustment about the number of vibrators that can be used with this machine.
	Circuit protector switch malfunction?	Immediately stop using. Inspect the wiring and control substrate. Replace the breaker switch assembly. Replace substrate if broken.
	Power source and control substrate trouble (mounted parts and circuit breakage)?	Immediately stop using. Inspect and repair this machine. (Depending on the condition of the trouble of the substrate, red LED lamp turns ON. Output of this machine stops. However, depending on the condition of the trouble of the substrate, LED lamp does not turn ON.)

TROUBLESHOOTING

Troubleshooting (Frequency Inverter)		
Power is turned on, but the machine stops running.	Main power is cut (Circuit protector switch is turned OFF)?	Check the power source voltage and the area of electric leakage, and also do inspection and check of the equipment and machine using the same power source. If there is no problem, turn on the main power. (Circuit protector switch is turned ON.) If abnormality is found with the power source, replace the power source.
	Power source electric leakage (inside of this machine or vibrator side)?	Immediately stop using. Check the area of electric leakage, and replace or repair.
	Power source and control substrate trouble (mounted parts and circuit breakage)?	Immediately stop using. Inspect and repair this machine.
	Damage or breakage of main vibrator and this machine?	Inspect and identify the breakage of stopped vibrator and the area of trouble. Replace or repair. (Depending on the condition of trouble, the red LED turns ON, and the output stops.)
	Trouble of control substrate (mounted parts and circuit breakage, etc.)?	Immediately stop using. Inspect and repair this machine.
	Circuit protector switch trouble?	Immediately stop using. Inspect the wiring and control substrate. Replace circuit protector (depending on the condition of breakage, the substrate may be replaced.)
	Input plug of this machine came off from the power source?	After turning OFF the circuit protector of this machine and the switch of the vibrator, connect the male plug to the main power source securely.
	Male plug of the vibrator is not securely connected to the output outlet?	After turning the vibrator switch OFF, securely connect the male plug.
	The plug cover of output outlet is not properly engaged to the claw of the male plug of vibrator. Or the male plug claw is worn or damaged?	After turning the vibrator switch OFF, connect the male plug securely, then make sure the claw is properly engaged. If the claw is worn or damaged, replace the male plug.
	This machine is dropped or a strong impact was applied?	Before turning on the input power again, check inside and outside of this machine for damage. If abnormality is detected, immediately stop using, then repair.

TROUBLESHOOTING

Troubleshooting (Frequency Inverter)		
Operation Frequency (LED Display) Is Not Shown (no power)	Power plug is not connected to the power source?	After making sure the switch of this machine is turned OFF, connect to the power source. Then check the display. (If the switch is ON, turn it OFF.)
Operation Frequency (LED Display) Is Not Shown (with power)	Relay power connector on frequency display substrate is disconnected?	Check the relay power connector for breakage and damage. Then reconnect.
	Relay power connector on frequency display substrate is damaged, broken or get dirty?	Check the relay power connector for breakage and damage. Then reconnect.
	LED letters are missing?	Replace frequency display substrate assembly and Frequency Adjustment/ Abnormality Display SW.
Operation Of Frequency Adjustment Switch Is Disabled (no power)	Power plug is not connected to the power source?	After making sure the switch of this machine is turned OFF, connect to the power source. (If the switch is ON, turn to OFF.)
Operation Of Frequency Adjustment Switch Is Disabled (with power)	Frequency Adjustment/Abnormality Display SW wiring is disconnected?	Check the wiring for damage and breakage. Then reconnect.
	Frequency Adjustment/Abnormality Display SW trouble?	Replacement of Frequency Adjustment/ Abnormality Display SW.
	Frequency display substrate, power source and control substrate trouble (mounted parts and circuit breakage, etc.)	Immediately stop using. Inspect and repair this machine.
Unable to adjust frequency. Only upward or only downward adjustment possible	Trouble of Frequency Adjustment/ Abnormality Display SW?	Replacement of Frequency Adjustment/ Abnormality Display SW
	Trouble of frequency display substrate, power source and control substrate (mounted parts and circuit breakage, etc.)?	Immediately stop using. Inspect and repair this machine.
Switches (C , S) not working	Wiring of Frequency Adjustment/ Abnormality Display SW is disconnected?	Check the wiring for breakage and damage. Then reconnect.
	Trouble of Frequency Adjustment/ Abnormality Display SW?	Replace of Frequency Adjustment/ Abnormality Display SW
	Trouble of frequency display substrate, power source and control substrate (mounted parts and circuit breakage, etc.)?	Immediately stop using. Inspect and repair this machine.
Anti-vibration rubber is broken	Breakage and separation of anti-vibration rubber due to strong impact applied and falling of the machine during transportation and handling?	Replace anti-vibration rubber.

OPERATION MANUAL

HERE'S HOW TO GET HELP

PLEASE HAVE THE MODEL AND SERIAL
NUMBER ON-HAND WHEN CALLING

UNITED STATES

Multiquip Inc.

(310) 537- 3700
6141 Katella Avenue Suite 200
Cypress, CA 90630
E-MAIL: mq@multiquip.com
WEBSITE: www.multiquip.com

CANADA

Multiquip

(450) 625-2244
4110 Industriel Boul.
Laval, Quebec, Canada H7L 6V3
E-MAIL: infocanada@multiquip.com

UNITED KINGDOM

Multiquip (UK) Limited Head Office

0161 339 2223
Unit 2, Northpoint Industrial Estate,
Globe Lane,
Dukinfield, Cheshire SK16 4UJ
E-MAIL: sales@multiquip.co.uk

© COPYRIGHT 2022, MULTIQUIP INC.

Multiquip Inc, the MQ logo are registered trademarks of Multiquip Inc. and may not be used, reproduced, or altered without written permission. All other trademarks are the property of their respective owners and used with permission.

This manual MUST accompany the equipment at all times. This manual is considered a permanent part of the equipment and should remain with the unit if resold.

The information and specifications included in this publication were in effect at the time of approval for printing. Illustrations, descriptions, references and technical data contained in this manual are for guidance only and may not be considered as binding. Multiquip Inc. reserves the right to discontinue or change specifications, design or the information published in this publication at any time without notice and without incurring any obligations.

Your Local Dealer is:

