

THE ELECTRIC SCREED BY **MAGIC SCREED**



E-SCREED OWNER'S MANUAL & PARTS LIST

Congratulations on your selection of the new *E-Screed HDE-2020* manufactured by Magic Screed.

E-Screed is solely designed to smooth and level wet concrete. Any other use of this tool could cause **permanent damage to the tool, inflict injuries or even death** to operator or surrounding coworkers.

To operate this tool, it is required to use the *E-screed battery pack model HBE-2020*. Any other power source than **HBE-2020** could permanently damage the electric and electronic systems of your screed.

Risk of electrocution, fire or explosion could occur. **Refer to the HBE-2020 owner's manual for operation and maintenance of your battery pack.**



SAFETY

- 1 Read and understand the owner's manual before operating or servicing your *HDE-2020 E-Screed* and *HBE-2020 battery pack*.
- 2 Have a first aid kit available in case someone gets injured.
- 3 Wear the appropriate safety gear (according to your local laws and requirements).



Unfortunately, it is impossible to warn you about all the hazards associated with the operation and maintenance of your E-Screed. You must use your own good judgement.

TABLE OF CONTENTS

Introduction	p. 2	Blades	p. 7
Safety	p. 2	Proper care and usage	p. 7
Assembly	p. 3	Parts list	p. 9
Labels	p. 6	Parts breakdown	p. 10
Specification	p. 7	Parts assembly	p. 11

ASSEMBLY

1 Remove the components from the box, discard protective packaging and box.



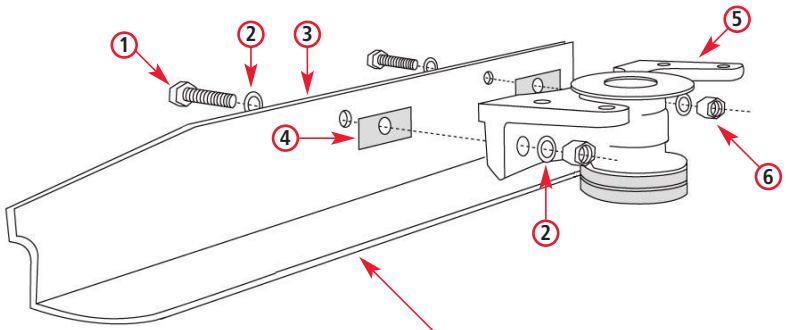

2 **Assembly of the blade.** Assemble the blade on the power unit vibrator housing in the following order: bolt (1) washer (2) blade (3) plastic spacer (4) housing (5) washer (2) nut (6). Tighten the bolts at **90 to 100 lb-ft torque**. It is very important that the plastic spacers are always between the blade and the vibrator. They are used as a cushion and prevent damage. Failure to install the spacers will void your warranty. Replacement spacers part #10002 are available at your Magic Screed dealer.



3 **Assembly of the tilt-up stand.** Place the stand with the flat side against the support bracket making sure you put the nylon washer on each side of the stand. Do not overtighten.





- 4 Adjustable handle assembly.** Insert the handles into the base frame with the throttle control on the right-hand side of the operator. Adjust the handle to suit your best comfort keeping in mind that the screed will float on the concrete and you will be standing lower in the wet concrete. Tighten the collar with the supplied Allen key. Keep it handy for future adjustment.



- 5 Connect the throttle to the drive box.** Insert and lock the connector to the drive box with connector arrows facing out.



- 6 Install the tool side cable.** Clip the cable on the right-hand side handle along the throttle cable. Do not tangle the two cables. The clips are designed to easily detach from the handles. This is to prevent damage to the power cable if you move too far away from the screed or you forget to disconnect your cable from the battery cable.

Note: Red clips go on the red section of the screed, black clips go on the chrome handle section.

LABELS

1 Warning logos



2 Serial number

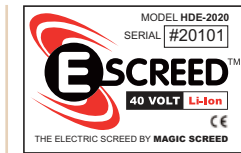

3 Model and manufacturer information

 THE ELECTRIC SCREED BY MAGIC SCREED	MODEL HDE-2020		POWER UNIT CE	
	YEAR	2020	MASS.	KG 14,1
	40V DC		LB	31
	ELECTRIC MOTOR		RPM	10500
Manufactured by: MAGIC SCREED 630, rue de l'Argon Québec (Qc) Canada, G2N 2J6		KW	0,65	



E-SCREED SPECIFICATION

Models Description and Weight LB/KG

- **HDE-2020** Battery powered screed with adjustable handles, 40V brushless DC motor, 10500 rpm high frequency vibrator.
- **HDE-2121** Battery powered screed with adjustable handles, extra Vibro mounts, 40V brushless DC motor, 10500 rpm high frequency vibrator.
- **Blades** Fit all power units (Electric/Gas). All interchangeable (custom size blade available on special order).

Model	Weight	
	LB	KG
HDE-2020	31	14.1
HDE-2121	31	14.1

Part #	FT	M	Weight	
			LB	KG
2050	4	1.22	6.7	3
2051	6	1.80	10.1	4.6
2052	8	2.44	13.4	6.1
2053	10	3.00	16.8	7.6
2054	12	3.66	20.2	9.2
2055	14	4.27	23.5	10.7
2056	16	4.88	26.9	11.77

PROPER CARE AND USAGE

BLADE

- Select the size of blade required for the type of work you will be performing.
- Make sure there is no concrete buildup at the bolting points or underneath the screed vibrator.
- Using the OEM bolt assembly (DA-4061) attach the blade to the power unit in the following order: bolt, washer, blade, plastic spacers, vibrator, washer, nut.

Tighten the bolts at **90 to 100 lb-ft torque**. It is very important that the plastic spacers are always between the blade and the vibrator. They are used as a cushion and prevent damage. **Failure to install the spacers will void your warranty.**

POWER UNIT

- Adjust your handles to suit your comfort using the supplied 6mm Allen key (10056).
- Make sure that all the power unit electric cables are undamaged, cut or spliced.
- Make sure that all connectors are inserted properly, clean and free of dust, concrete, water, humidity or flammable product such as oil.

All connectors are shaped differently and can only fit at one location.

No force should be applied.

BATTERY AND HARNESS

- Make sure your battery cable is undamaged and clean.
- Make sure that the power cable on the power unit is not tangled with the throttle cable and free to unclip without damaging it. *The clips are designed to unclip easily so if the operator forgets to unplug from the power unit, it will not create damage to the connectors or cable.*
- Connect your power cable to the battery.
- Adjust your harness to suit your comfort.
- Connect your fully charged E-screed battery *model HBE-2020* to your power unit.

Only the E-Screed battery model HBE-2020 can be used with the E-Screed model HDE-2020.

Details and specifications of the battery can be consulted in the battery owner's manual supplied with the HBE-2020.

OPERATION

E-Screed is solely designed to smooth and level wet concrete. Any other use of this tool could cause *permanent damage to the tool, inflict injuries or even death* to operator or surrounding coworkers.

- Connect the battery cable to the power cable on the E-Screed.
- Place the Screed on wet concrete.
- Gently twist the throttle to activate the vibration.

- Control the amount of vibration required and adjust your pace to smooth and level the concrete according to the slump and aggregate.

Generally, the Screed is operated at 1/2 to 3/4 throttle. Over vibration will create premature wear of the tool, faster discharge of the battery and lack of precision.

CLEANING AND MAINTENANCE

- Always disconnect the battery from the power unit before performing any cleaning and maintenance to prevent risk of electrocution, short circuit of the electric and electronic components.
- Scrub and clean any concrete accumulation off the power unit and blade.

Do not pressure wash.

Do not use chemicals or any type of acid.

- The blade should be disassembled as frequently as possible to clean any concrete accumulations underneath and surrounding the vibrator.
- Inspect the power unit for any loose bolt or damaged connectors.
- Verify the plastic spacers for any damage and torque the blade bolts to 90 to 100 lb/ft.
- Store the screed in a dry and tempered area.
- *Charge the E-Screed battery according to the procedure in your battery manual.*
- *Only use the E-Screed charger supplied with your battery.*

PARTS

ITEM	DESCRIPTION	PART #	QTY
1	PLASTIC SPACER	10002	2
2	VIBRO MOUNT	10003	2
3	RUBBER COVER	10009-2	1
4	BOLT 1/2	10017	2
5	NUT 1/2	10018	2
6	WASHER 1/2	10019	4
7	WASHER 8mm	10023	8
8	NUT 8mm	10024	16
9	DRIVE AXLE	10025	1
48	ALLEN KEYS 5 & 6 mm	10056	1
10	STAND	20013-1	1
11	STAND RUBBER	20014	1
12	BOLT 1/4	20017	1
13	NUT 1/4	20018	1
14	6mm NYLON FOR STAND	20023	2
16	POP 1/8 FOR STAND RUBBER	20027	2
17	ADJ. HDL. GRIP SECTION	20032-2	2
18	ADJ. HDL LONG SECTION	20032-3	2
19	CLIP FOR HANDLES	20033	4
21	TIE WRAP	20040	1
22	ANTI-VIBRATION SEAL	50002	1
23	CAP 8	50005	1
32	RUBBER TUBE	50009	1
26	E-SCREED GRIP	E-60004	2
27	HOUSING WEIGHT SHAFT	E-60123	1
28	HOUSING WEIGHT E-SCREED	E-60124	1
29	COUNTER WEIGHT E-SCREED	E-60125	1
30	CIRCLIP 15MM	E-60126	1
31	HOUSING WEIGHT BEARING	E-60200	2
24	E-SCREED HANDLE 2020	E-70004	1
33	25,4MM X 4MM CLIP	E-70034-A	1
34	25,4MM X 10,4MM CLIP	E-70034-C	1
35	22,2MM X 4MM CLIP	E-70034-D	2
36	22,2MM X 10,4MM CLIP	E-70034-F	1
37	BATTERY CABLE	E-70230	1
38	TOOL SIDE CABLE	E-70231	1
39	MOTOR AND GEARBOX ASSY.	KE-7010	1
40	THROTTLE ASSY	KE-7030	1
41	DRIVE ASSY	KE-7040	1
42	CONTROL BOX NUT	E-60008	4
43	CONTROL BOX BOLT	E-60009	4

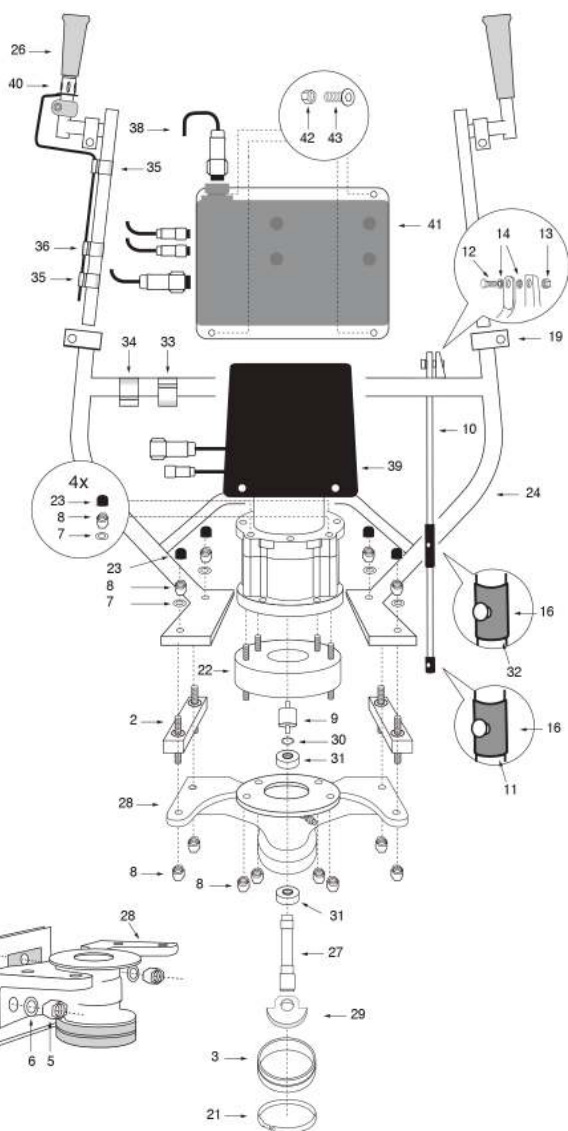
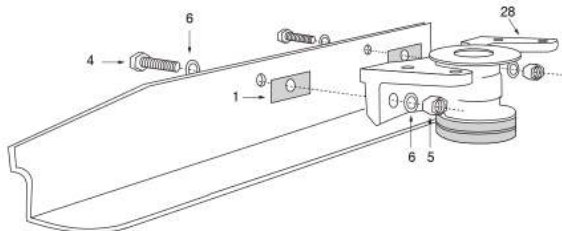
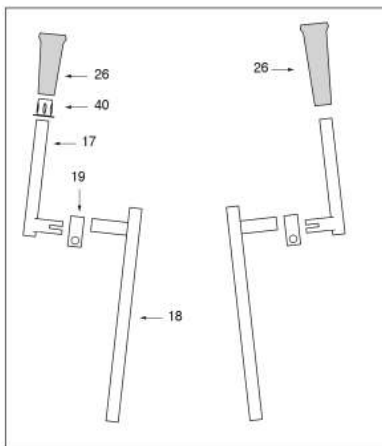
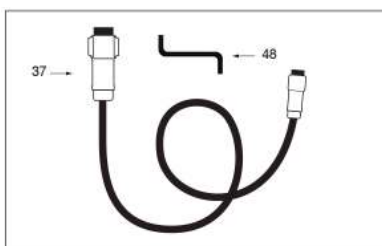

E-SCREED PARTS ASSEMBLY

DA 4055 RUBBER COVER ASSEMBLY

PART NUMBER	QTY	DESCRIPTION
10009-2	1	RUBBER COVER
20040	1	TIE WRAP



DA 4059 VIBRO MOUNTS

PART NUMBER	QTY	DESCRIPTION
10003	2	VIBRO MOUNTS
10024	8	NUT 8 MM
10023	4	WASHER 8 MM

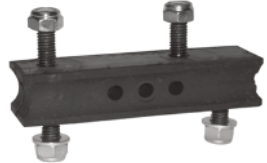

DA 4059-X X-TRA VIBRO MOUNTS

PART NUMBER	QTY	DESCRIPTION
11003	2	X-TRA VIBRO MOUNTS
10024	8	NUT 8 MM
10023	4	WASHER 8 MM

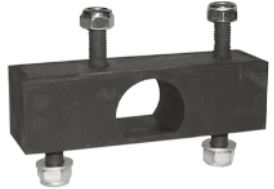

DA 4061 BOLT & NUT 1/2

PART NUMBER	QTY	DESCRIPTION
10018	2	NUT 1/2
10017	2	BOLT 1/2
10019	4	WASHER 1/2
10002	2	PLASTIC SPACER

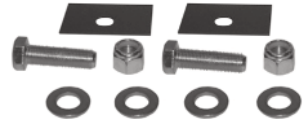

DA 4088 STAND ASSEMBLY

PART NUMBER	QTY	DESCRIPTION
20013-1	1	STAND
20018	1	NYLON NUT 1/4
20023	2	NYLON WASHER 1/4
20017	1	BOLT 1/4
20014	1	STAND RUBBER
20027	2	RIVET
50009	1	RUBBER TUBE



E-SCREED PARTS ASSEMBLY

DA 4097 ALLEN KEY 6 MM 5 MM

PART NUMBER	QTY	DESCRIPTION
10056	1	ALLEN KEY 6 MM 5 MM



DA 4098 TIE WRAP FOR 10009-2

PART NUMBER	QTY	DESCRIPTION
20040	10	TIE WRAP



DA 4100

PART NUMBER	QTY	DESCRIPTION
50002	1	ANTI VIBRATION SEAL
10024	8	NUT 8 MM



DA 4101

PART NUMBER	QTY	DESCRIPTION
50005	8	CAP FOR 8 MM NUT



E-60004 E-SCREED GRIP ASSEMBLY

PART NUMBER	QTY	DESCRIPTION
20012	1	GRIP (SET OF 2)



KE5050 BOLT CONTROL BOX

PART NUMBER	QTY	DESCRIPTION
KE5040	1	BOLT CONTROL BOX



KE5060 E-SCREED HOUSING WEIGHT ASSEMBLY

PART NUMBER	QTY	DESCRIPTION
KE5060	1	HOUSING WEIGHT



KE-7030 THROTTLE ASSEMBLY

PART NUMBER	QTY	DESCRIPTION
KE-7030	1	THROTTLE ASSY.



E-70231 TOOL SIDE CABLE

PART NUMBER	QTY	DESCRIPTION
E-70231	1	TOOL SIDE CABLE



KE-7010 MOTOR AND GEARBOX ASSEMBLY

PART NUMBER	QTY	DESCRIPTION
KE-7010	1	MOTOR AND GEARBOX ASSY.



E-70034 CABLE CLIP

PART NUMBER	DESCRIPTION	
E-70034-A	FRAME CLIP THROTTLE CABLE	RED-A
E-70034-C	FRAME CLIP POWER CABLE	RED-C
E-70034-D	HANDLE CLIP THROTTLE CABLE	BLACK-D
E-70034-F	HANDLE CLIP POWER CABLE	BLACK-F



E-SCREED PARTS ASSEMBLY

E-70000U BATTERY 40V 26.4A

PART NUMBER	QTY	DESCRIPTION
E-70000U	1	BATTERY 40V 26.4A



E-70400 CHARGER 110V 15A

PART NUMBER	QTY	DESCRIPTION
E-70400	1	CHARGER 110V 15A



E-70500 HARNESS

PART NUMBER	QTY	DESCRIPTION
E-70500	1	HARNESS



E-70230 BATTERY CABLE

PART NUMBER	QTY	DESCRIPTION
E-70230	1	BATTERY CABLE



HBE-2020 BATTERY PACK ASSEMBLY

PART NUMBER	QTY	DESCRIPTION
HBE-2020	1	BATTERY PACK, CHARGER, HARNESS, CABLE



KE-7040 DRIVE ASSEMBLY

PART NUMBER	QTY	DESCRIPTION
KE-7040	1	DRIVE ASSY.





4795, Louis-B.-Mayer St., Laval, Quebec, Canada H7P 6G5
SALES OFFICE Tel.: 1 450 978-0200 - Fax: 1 450 978-3623
PLANT Tel.: 1 418 849-5037 - Fax: 1 418 849-0501

Visit our Web site: www.magicscreed.com

E-Mail: info@magicscreed.com